

**Le diverse tipologie di macchine
irroratrici impiegate nei
trattamenti fitosanitari alle
colture agrarie: classificazione,
componenti, caratteristiche
costruttive, criteri di
funzionamento e di scelta.**



- **componenti**
- **funzionamento**
- **evoluzione nelle macchine**





problema tecnologico > distribuzione di un prodotto su una vasta superficie rappresentata dal terreno agrario o dalla vegetazione

macchine >

due requisiti:

1) dosare il prodotto

2) distribuirlo in modo uniforme*

* Approccio tradizionale vs “precision farming”

L'attrezzatura

“L'interfaccia del pesticida con l'ambiente”

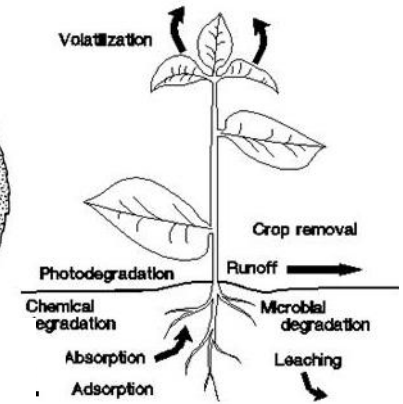
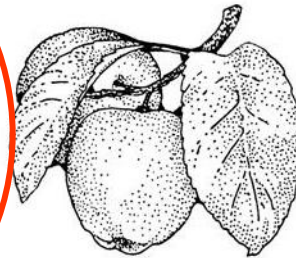
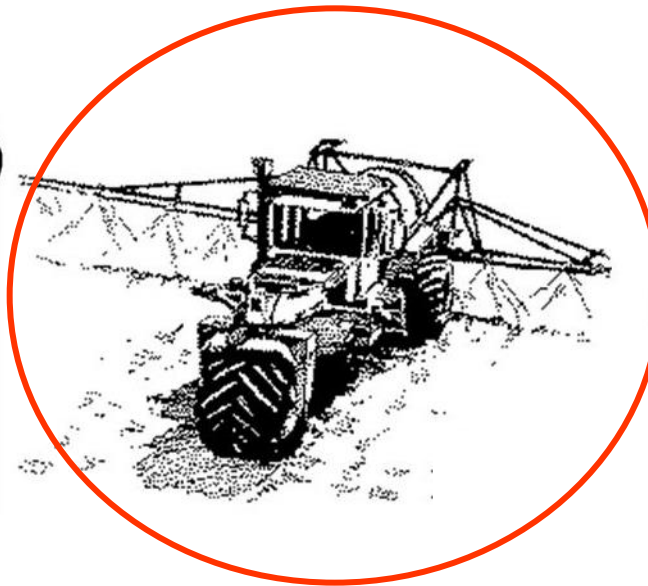
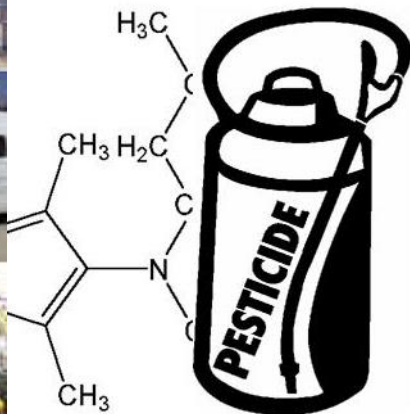

Attrezzature per la distribuzione dei prodotti fitosanitari

- Barre
- Atomizzatori – (getto portato)
- Irroratrici per applicazioni in banda
- Aereo / Elicottero
- A carriola
- Lance
- Treni
- Attrezzature motorizzate portate a
- Foggers
- Distributori di granuli
- Lance a spalla
- Impolveratrici
- Barre umettanti
- **Seminatrici**
- Fumigatrici





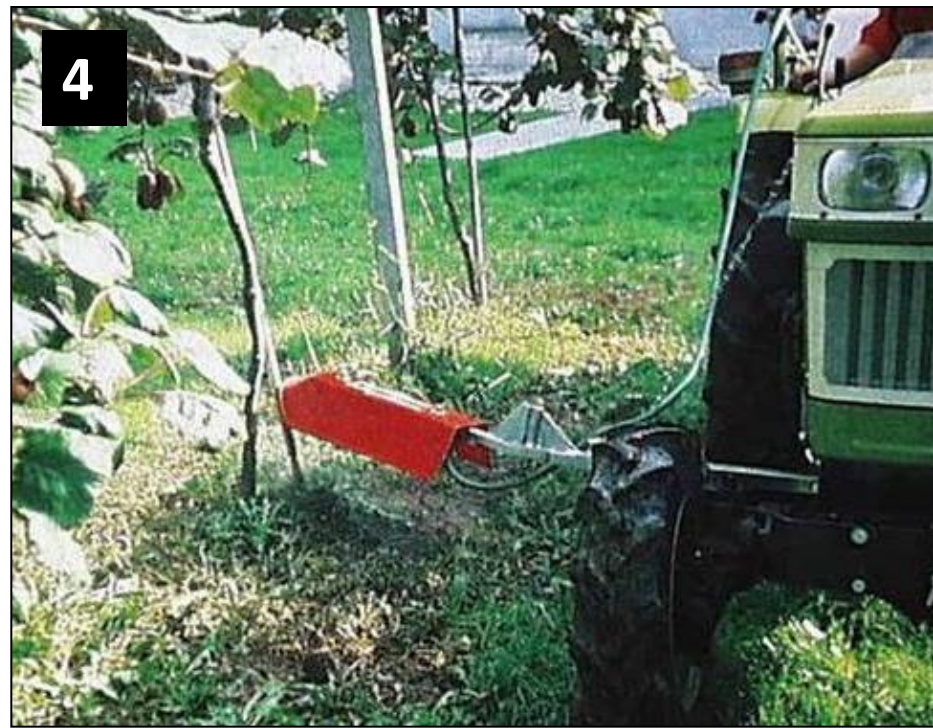

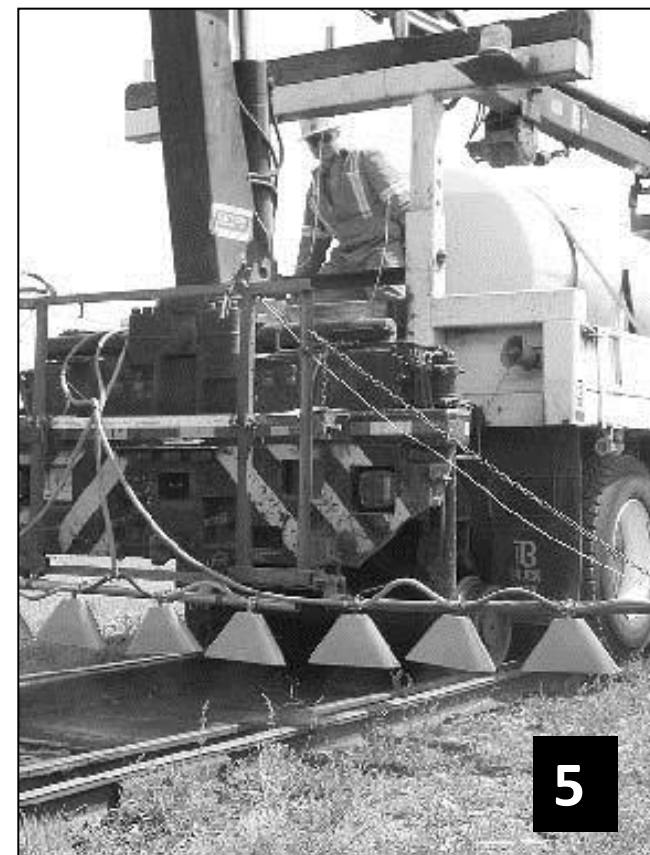

Classificazioni

Trasporto

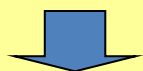

1. UOMO
2. TRATTORE
 - Portate
 - Trainate
3. SEMOVENTI
 - Terrestri
 - Aeree

Materiale distribuito



1. LIQUIDO
 - Irroratrici
 - Attrezzature speciali
2. POLVERI
 - (impolveratrici)
3. GAS
 - (fumigatrici)

Classificazione delle irroratrici portatili

1. Manuali

- 1. A Leva (LK)
- 2. A Compressione (CS)

2. Motorizzate

- 3. A nebulizzazione meccanica (idraulica) (MK)
- 4. Aeroassistite (MB)
- 5. Rotative (ugello centrifugo)

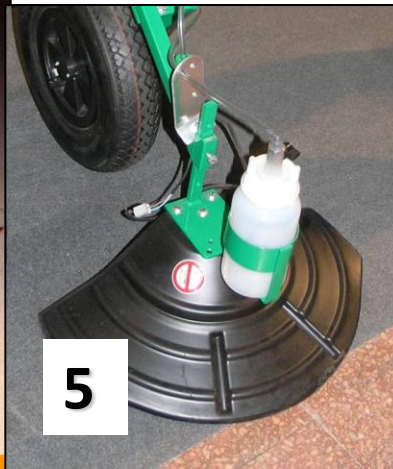

Attrezzature speciali



Endoterapia

Attrezzature speciali

Lance oscillanti (tipo "Casotti")



**Attrezzature
speciali**

**Prototipo di
piantatuberi
con
attrezzatura di
concia on-line**



Attrezzature speciali

Umettatrici



Attrezzature speciali Impolveratrici



Impolveratrice elettrostatica



Classificazione secondo il modo di formazione della goccia

1. Idraulico (= meccanico) tradizionale
con aero-assistenza
senza aero-assistenza



2. Pneumatico

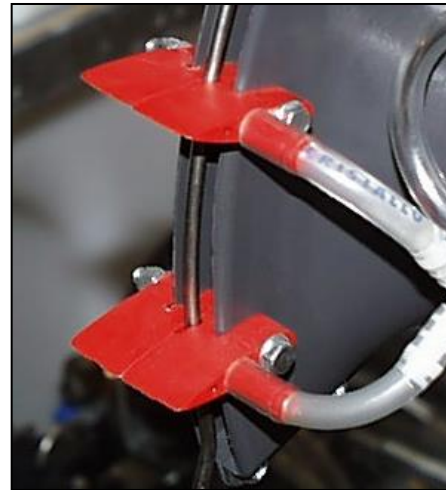

3. Centrifugo
con aero-assistenza
senza aero-assistenza

Irroratrici

- Parti e componenti



Componenti delle irroratrici



Componenti comuni

- Telaio
- Serbatoio

Circolazione dei fluidi

- Pompa
- Tubazioni
- Filtri
- Ventilatori

Organi di regolazione

- Manometro
- Compensatore idropneumatico
- Sistemi di regolazione della dose

➔ Ugelli

Accessori e parti speciali

Schema .1

Barra per le colture erbacee e il diserbo

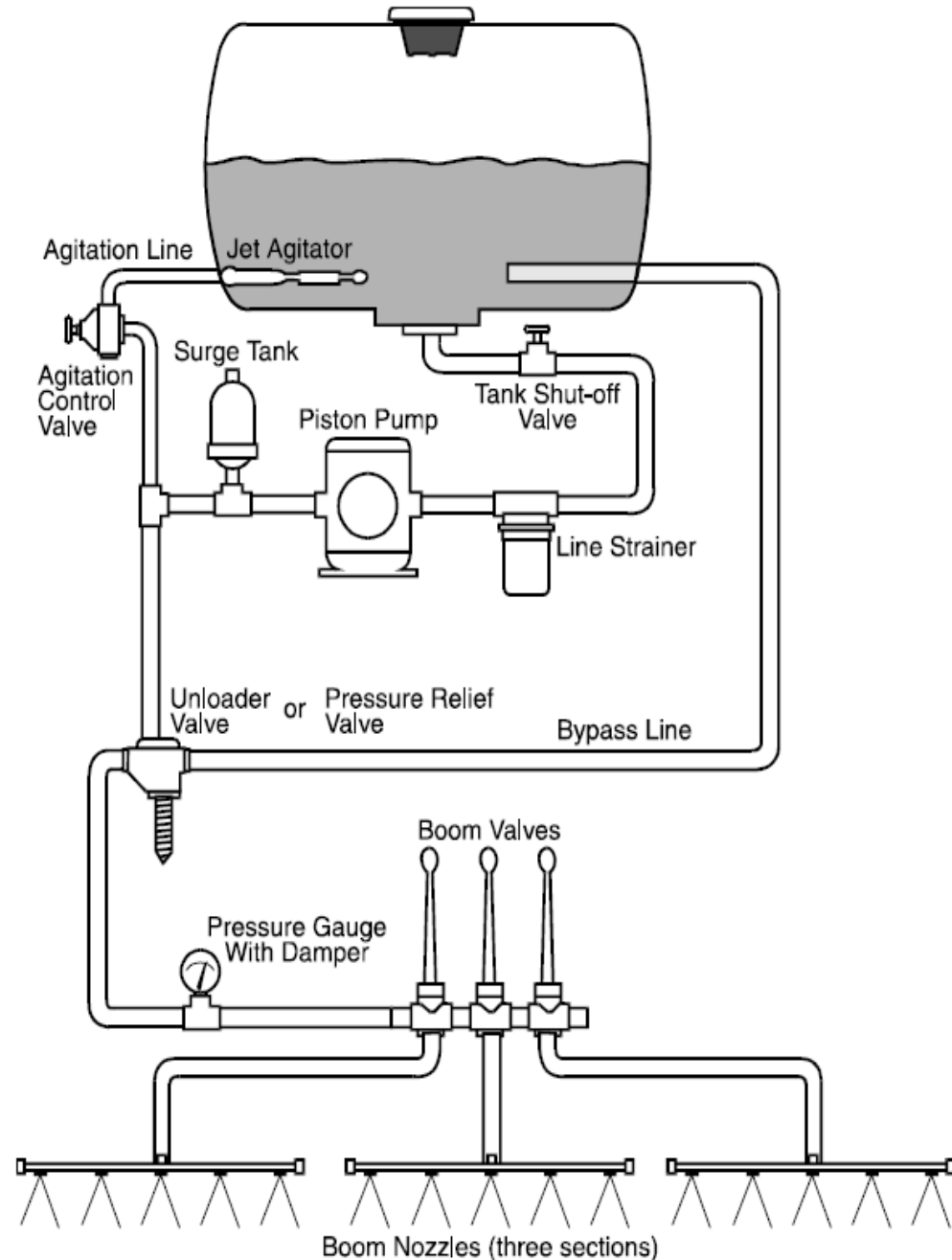

Schema .2

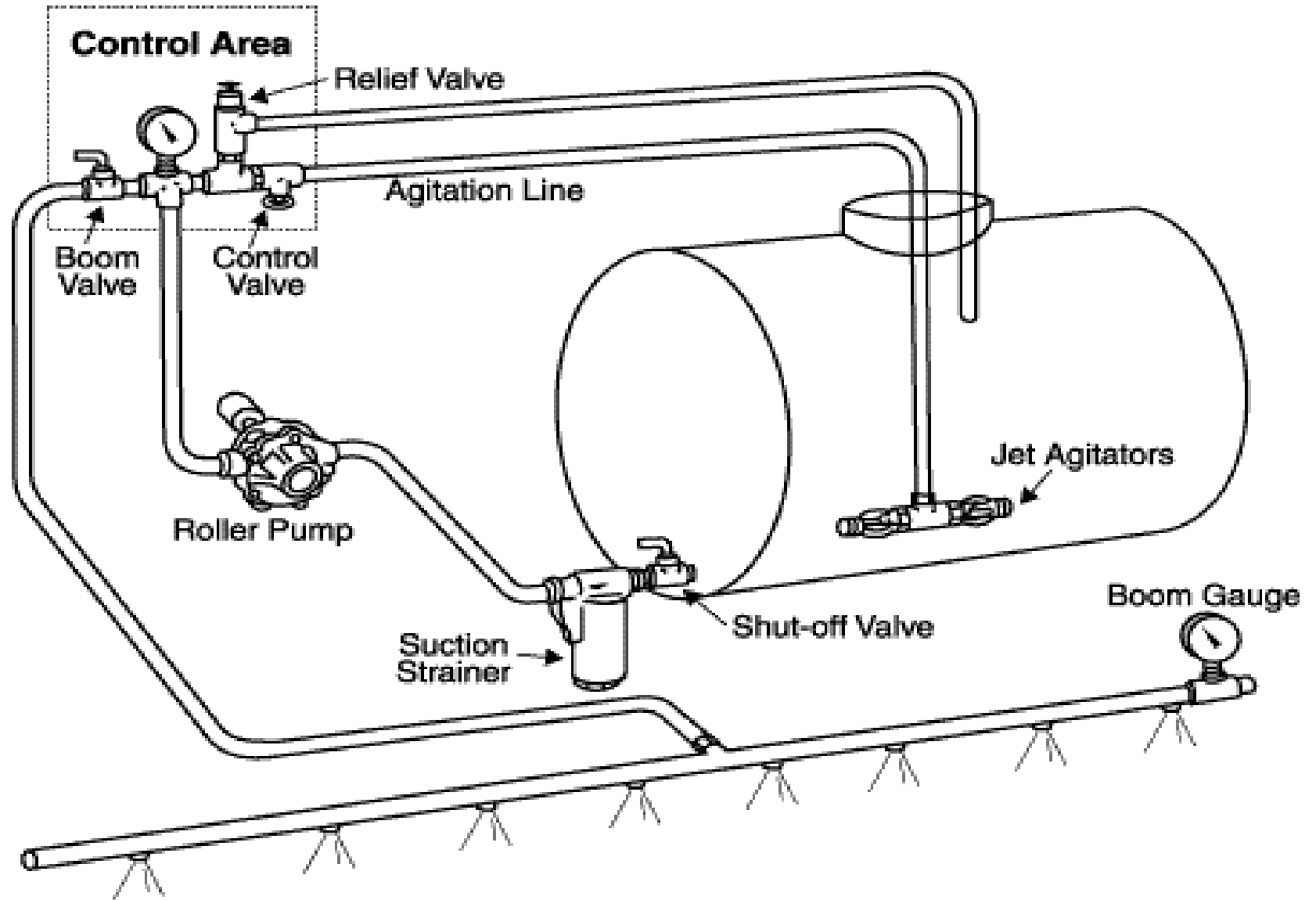

Schema .3

Aeroassistita – per le colture arboree

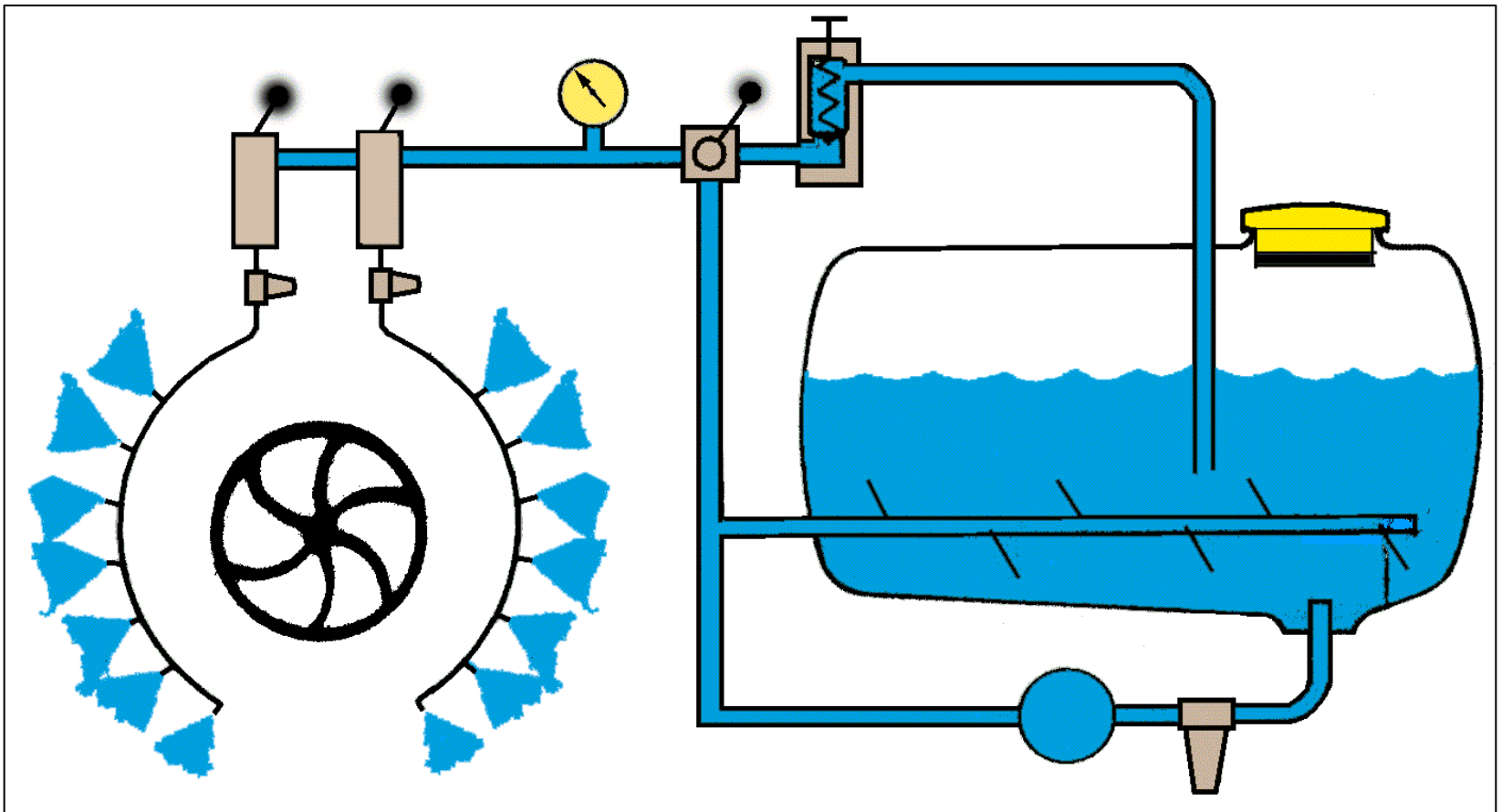

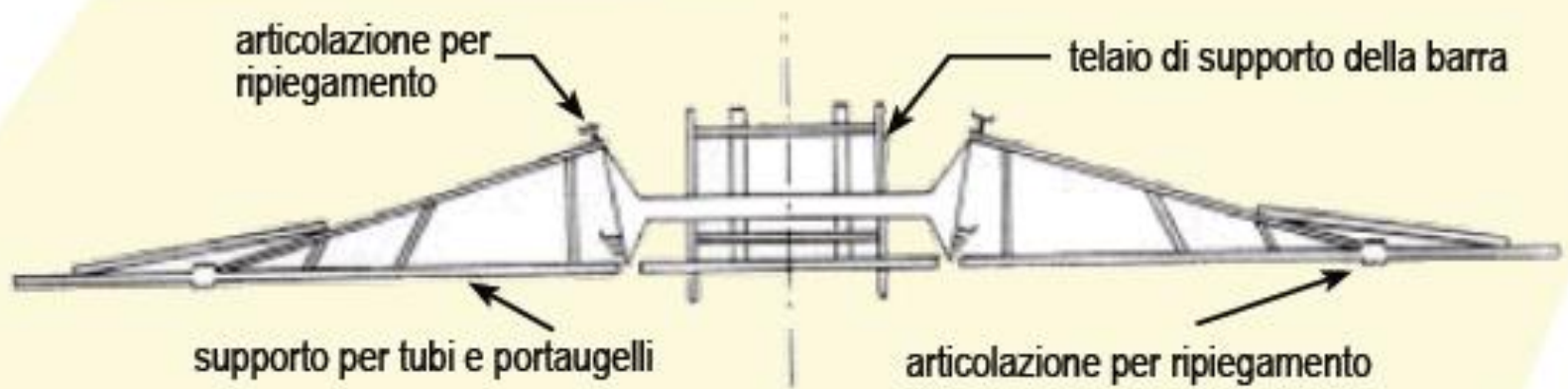

Schema costruttivo di una barra

Barra, componenti vari



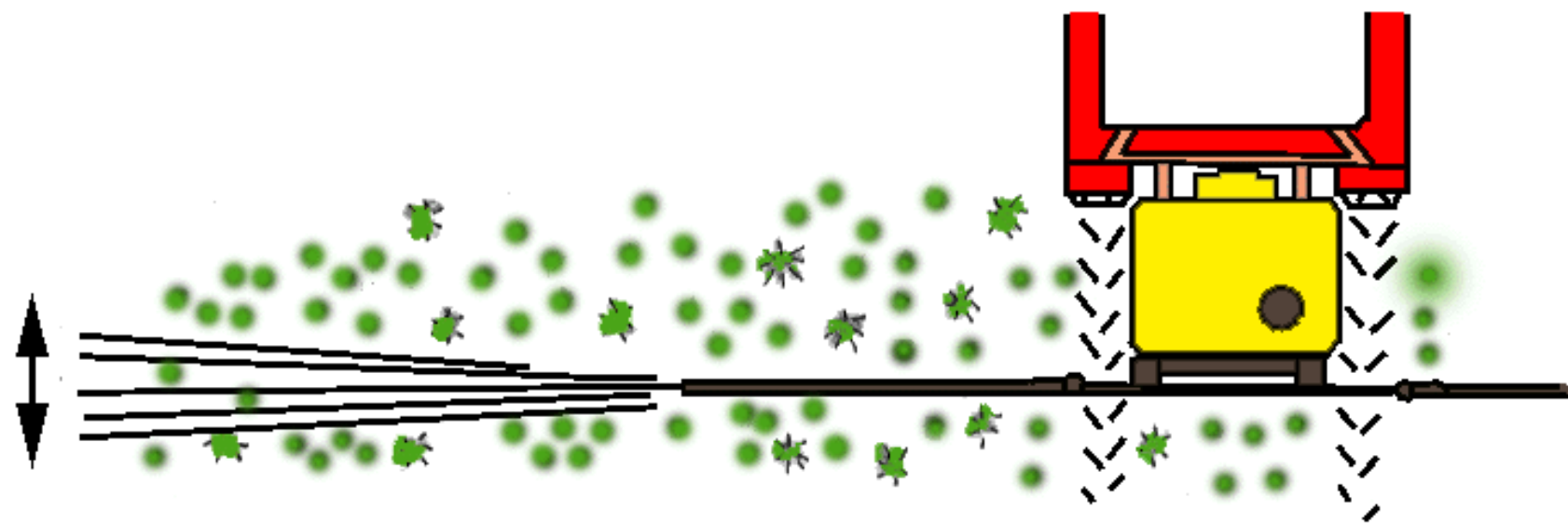
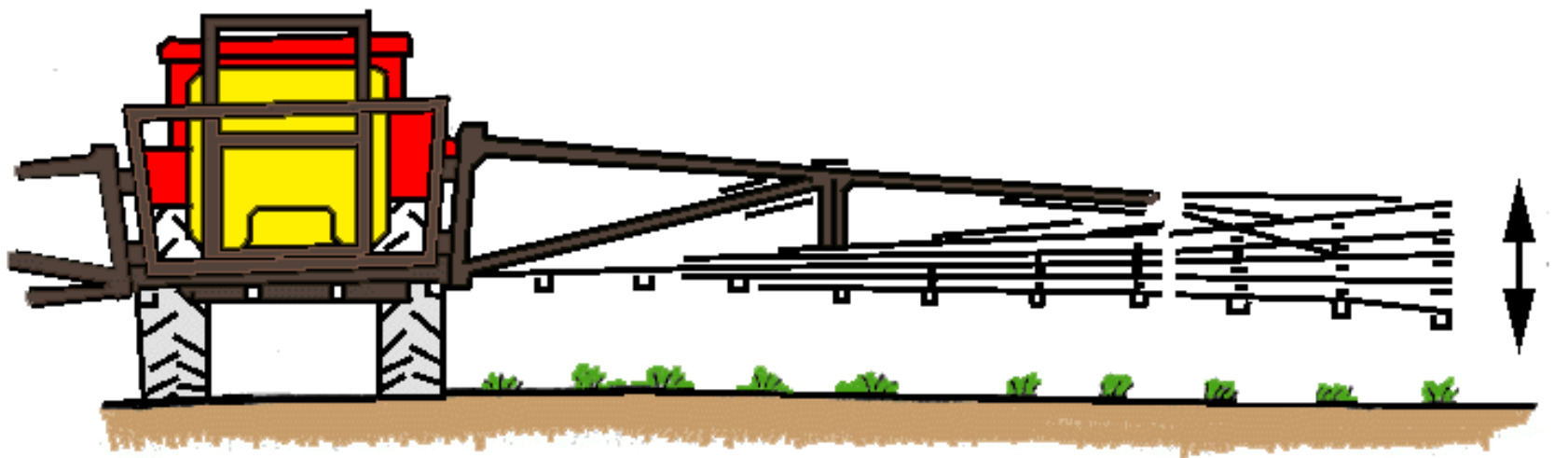

Movimenti della barra

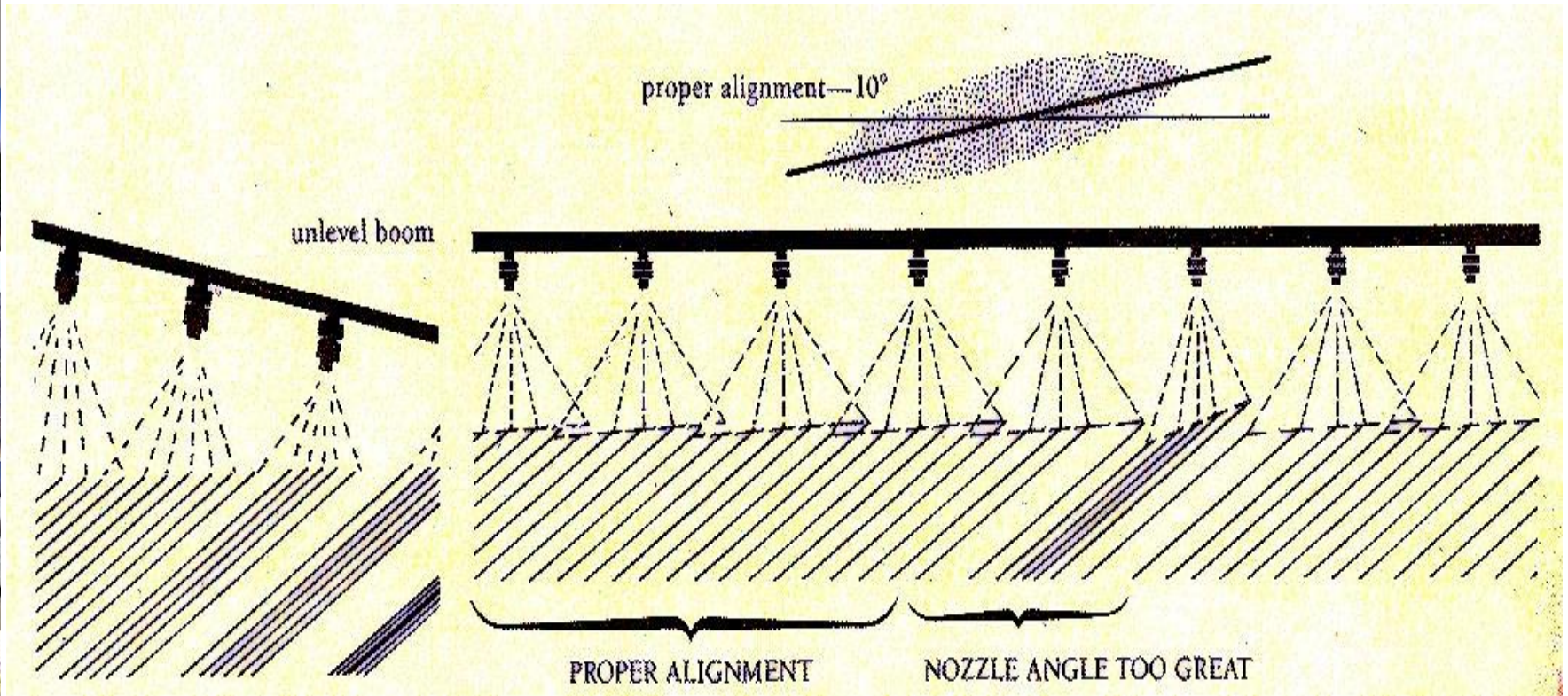

Allineamento ugelli a ventaglio e orizzontalità della barra



La pompa

- Centrifughe
- Volumetriche (alternative)
 - A pistoni
 - A membrana

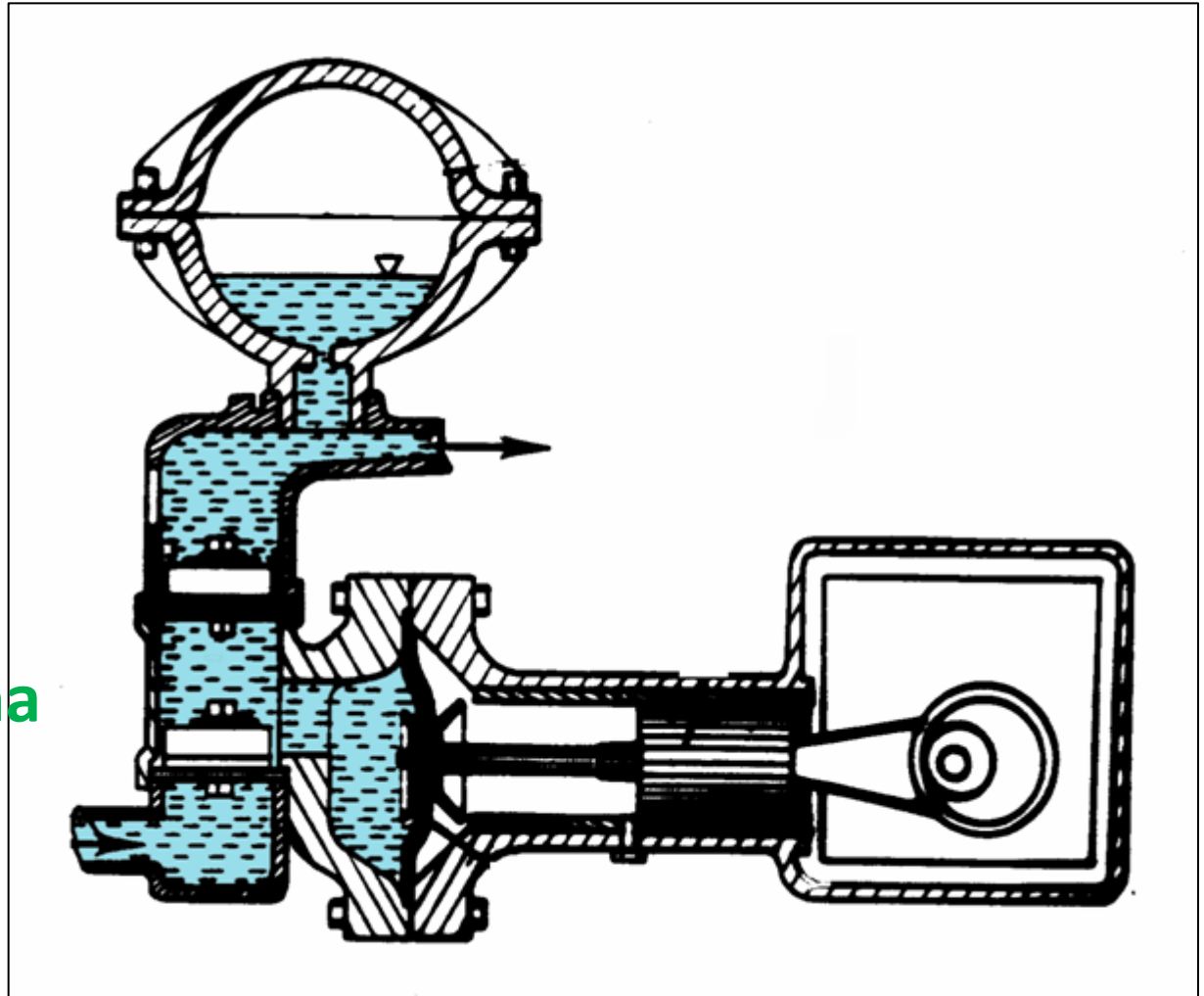

Pompa centrifuga

- Assicurano alte portate a basse pressioni
- Lavorano a elevato n° giri
- Sono usate nelle irroratrici per funzioni accessorie

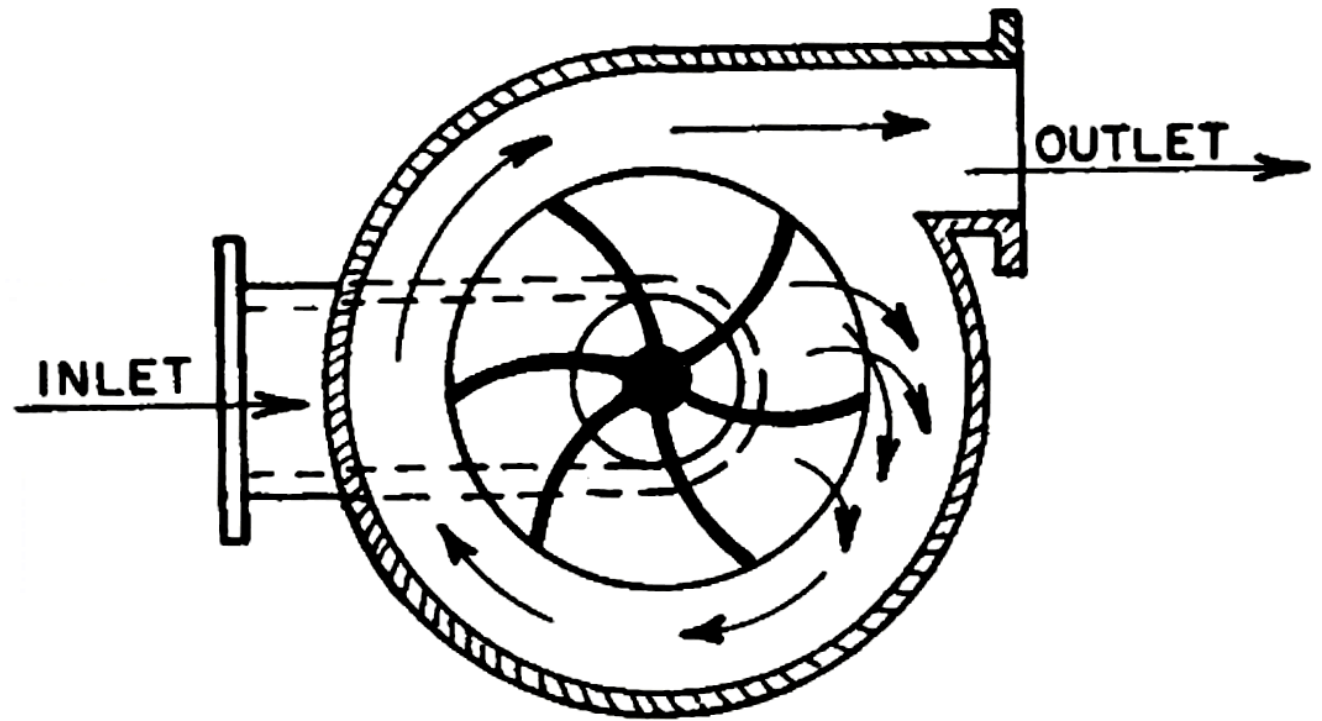

Pompa a membrana



Valvole



Compensatore idropneumatico

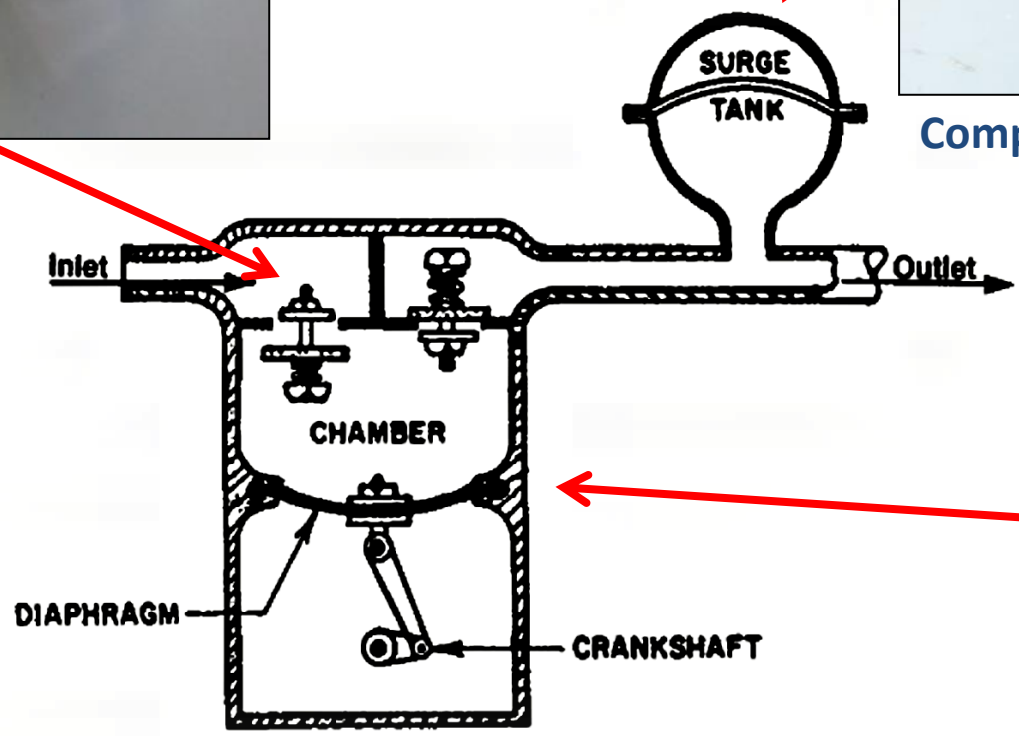

Membrana in polimeri speciali (Viton)

Pompa a pistoni

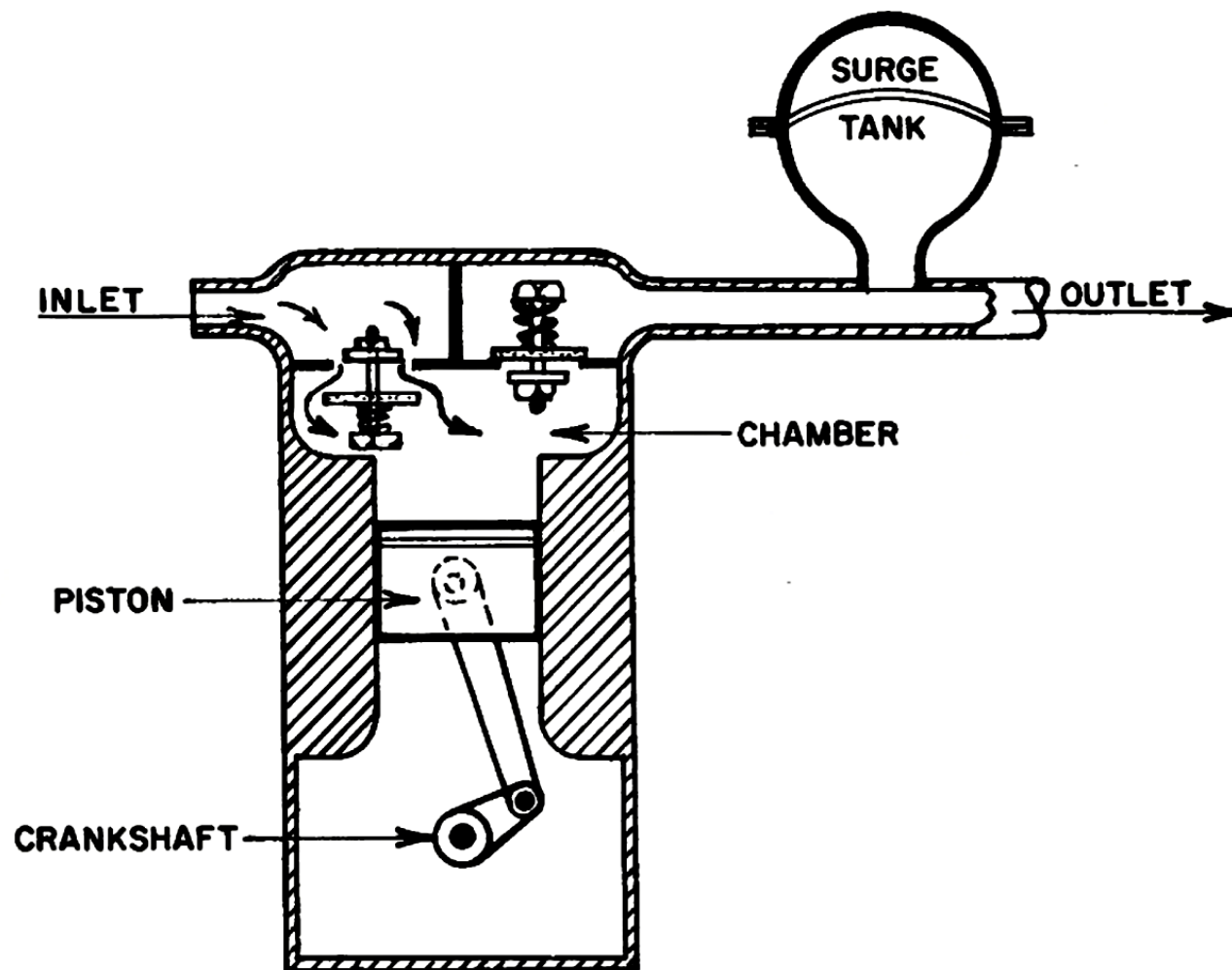

Pompa rotativa

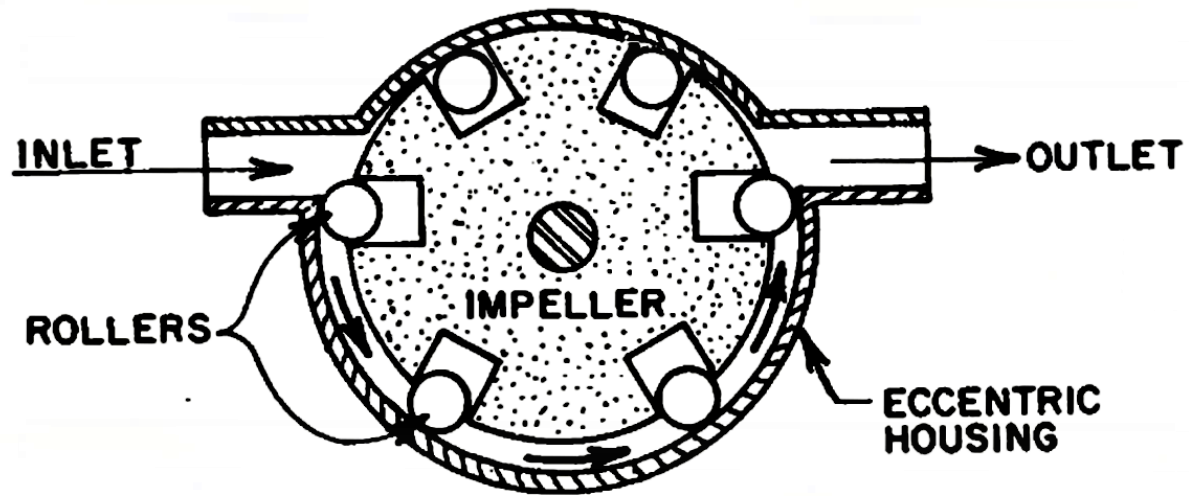

Nelle irroratrici eventuali servizi accessori

Caratteristiche delle pompe volumetriche

- Cilindrata
- Portata (= cilindrata x n° giri)
- Rendimento
- Pressione
- Potenza (= pressione x portata)
- (Pulsazione)



Pompa pistoni-membrana

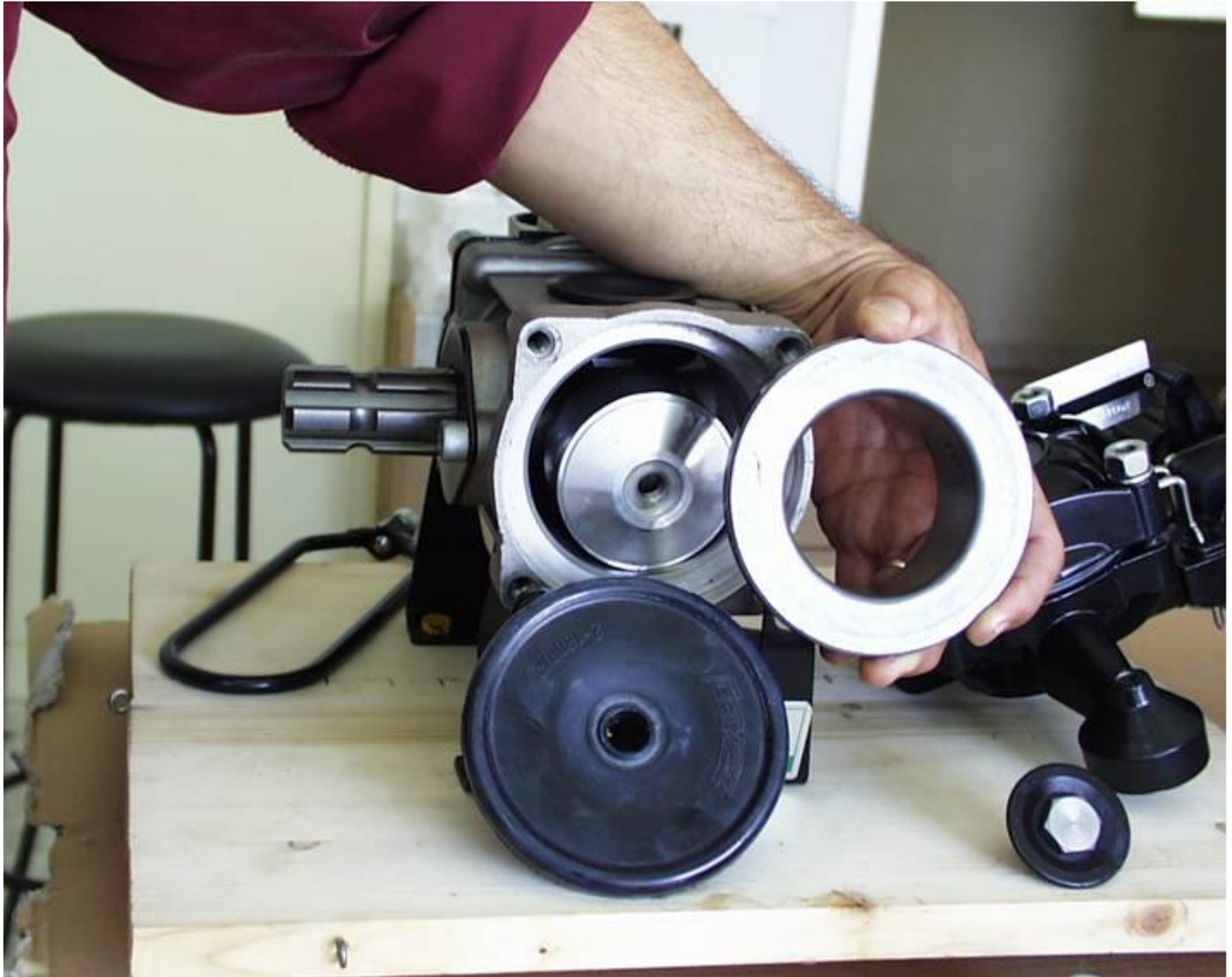

**POMPA A PISTONI-
MEMBRANA**
MEMBRANA DI ACCESSO ALLA
LUBRIFICAZIONE DELL'ALBERO

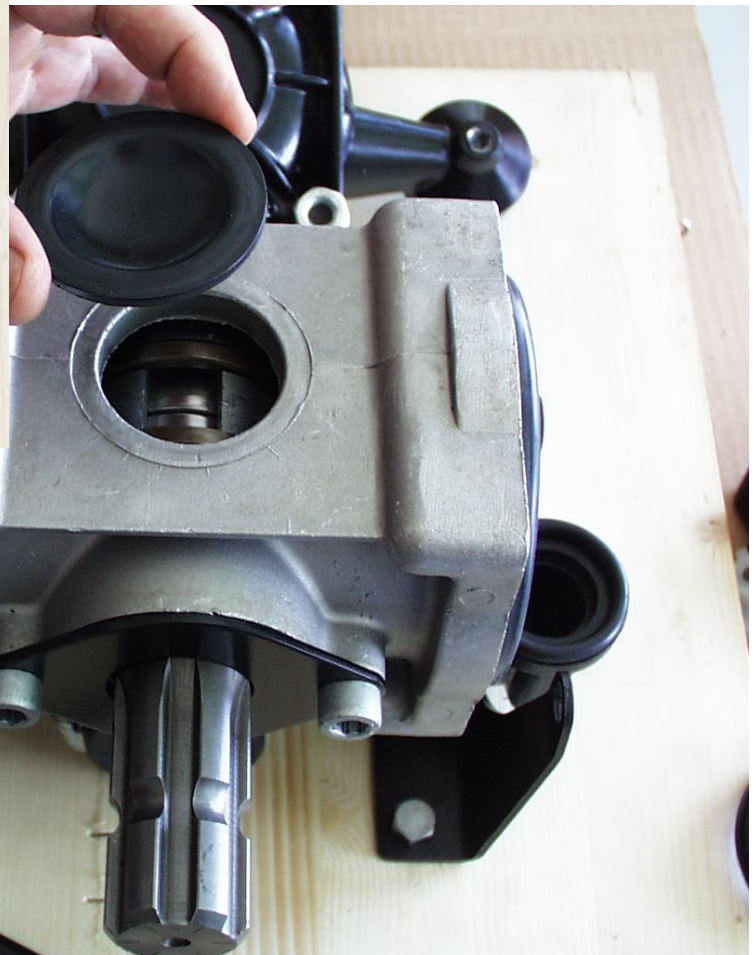
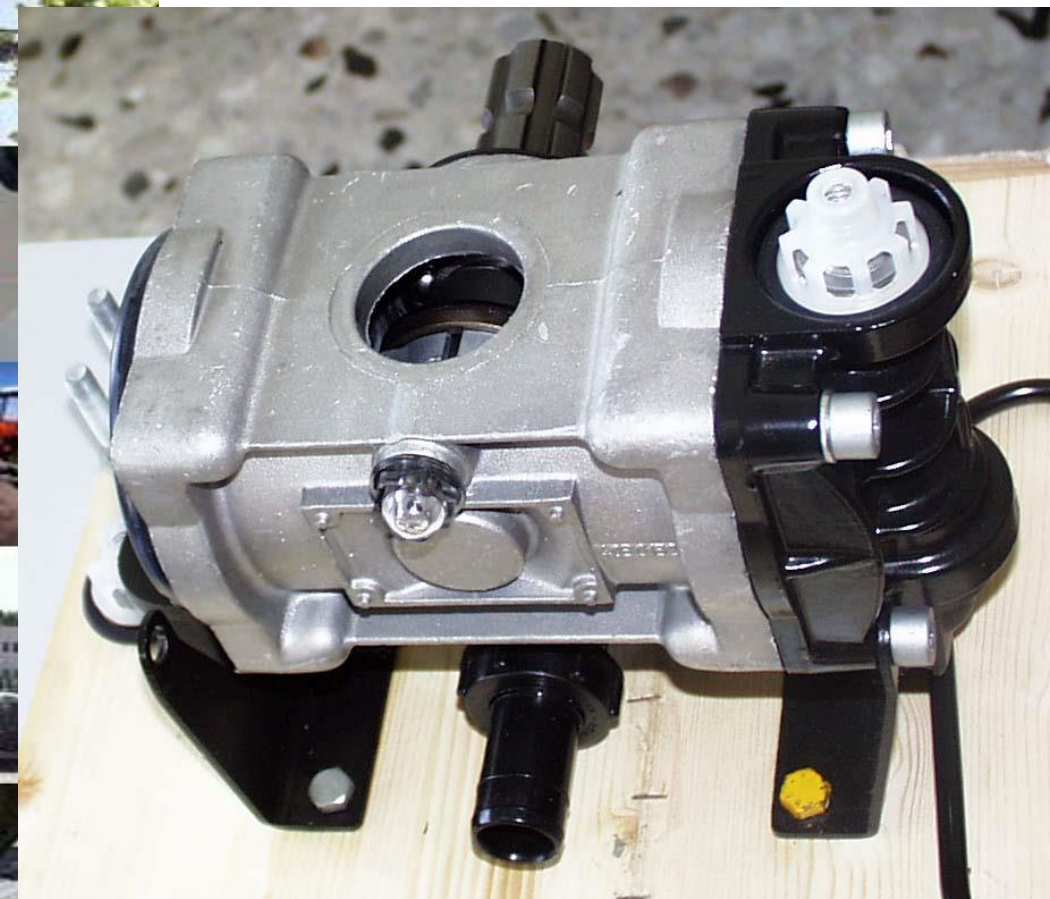

POMPA A PISTONI-MEMBRANA

PARTICOLARE DI UNA VALVOLA



POMPE A PISTONI

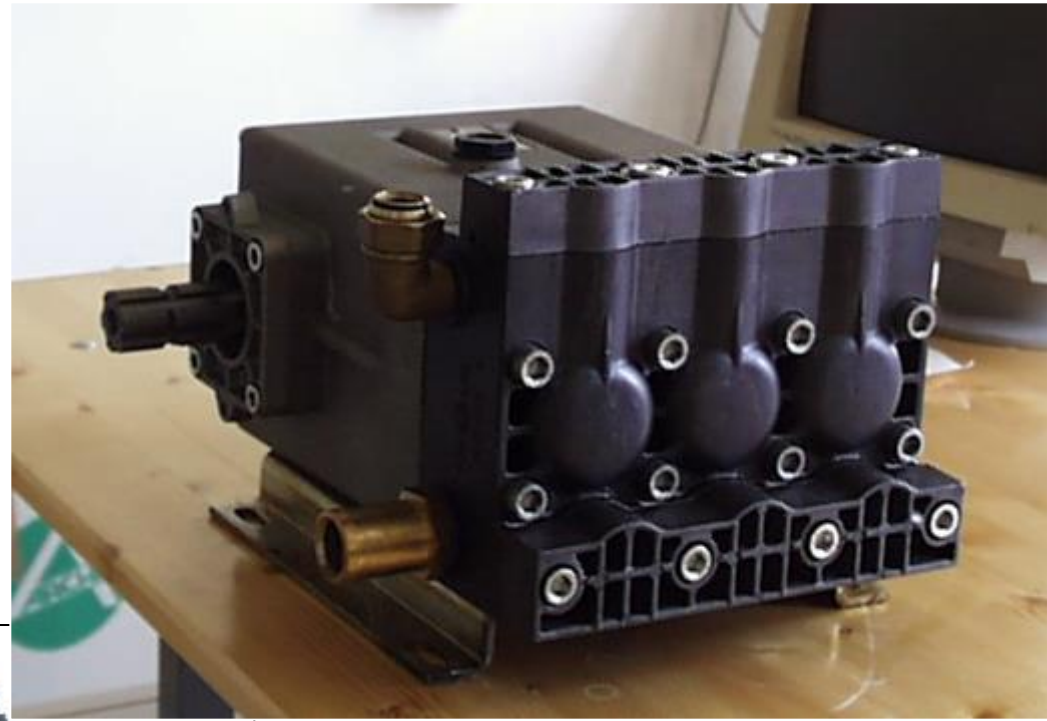

POMPA A PISTONI



PARTICOLARE DELL'ALBERO A CAMME





Valvola di sovrappressione
Bagno d'olio

Targhetta identificativa

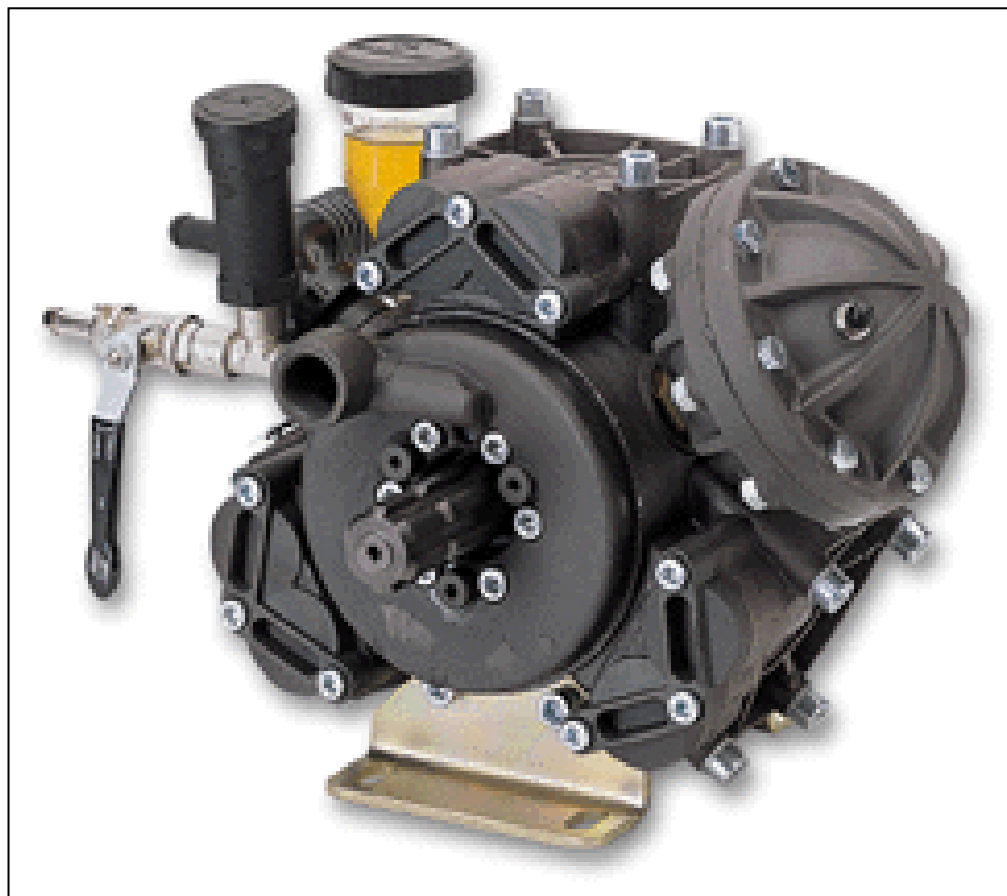

Pompa pistoni- membrana su un'atomizzatore

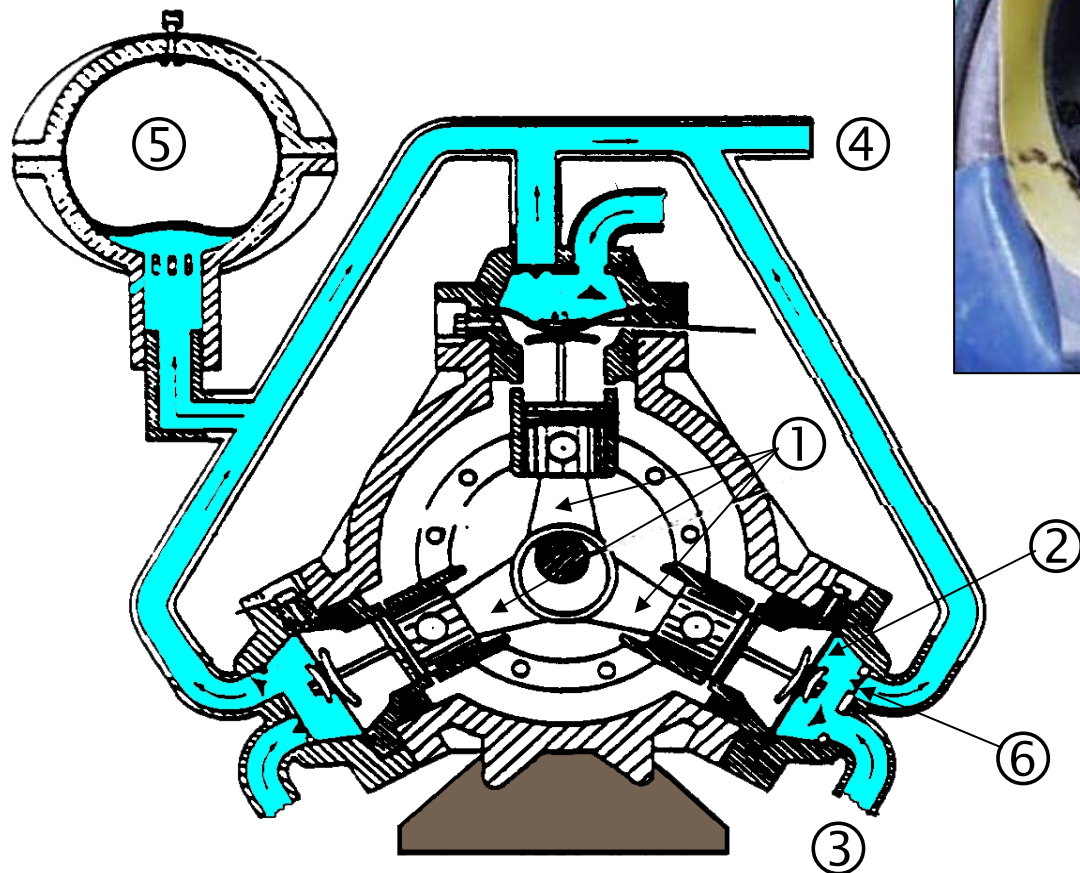

- 1 -Pistoni;
- 2 -Membrana;
- 3 -Aspirazione;
- 4 -Mandata;
- 5 -Accumulatore idraulico;
- 6 -Valvole.

Compensatore pneumatico

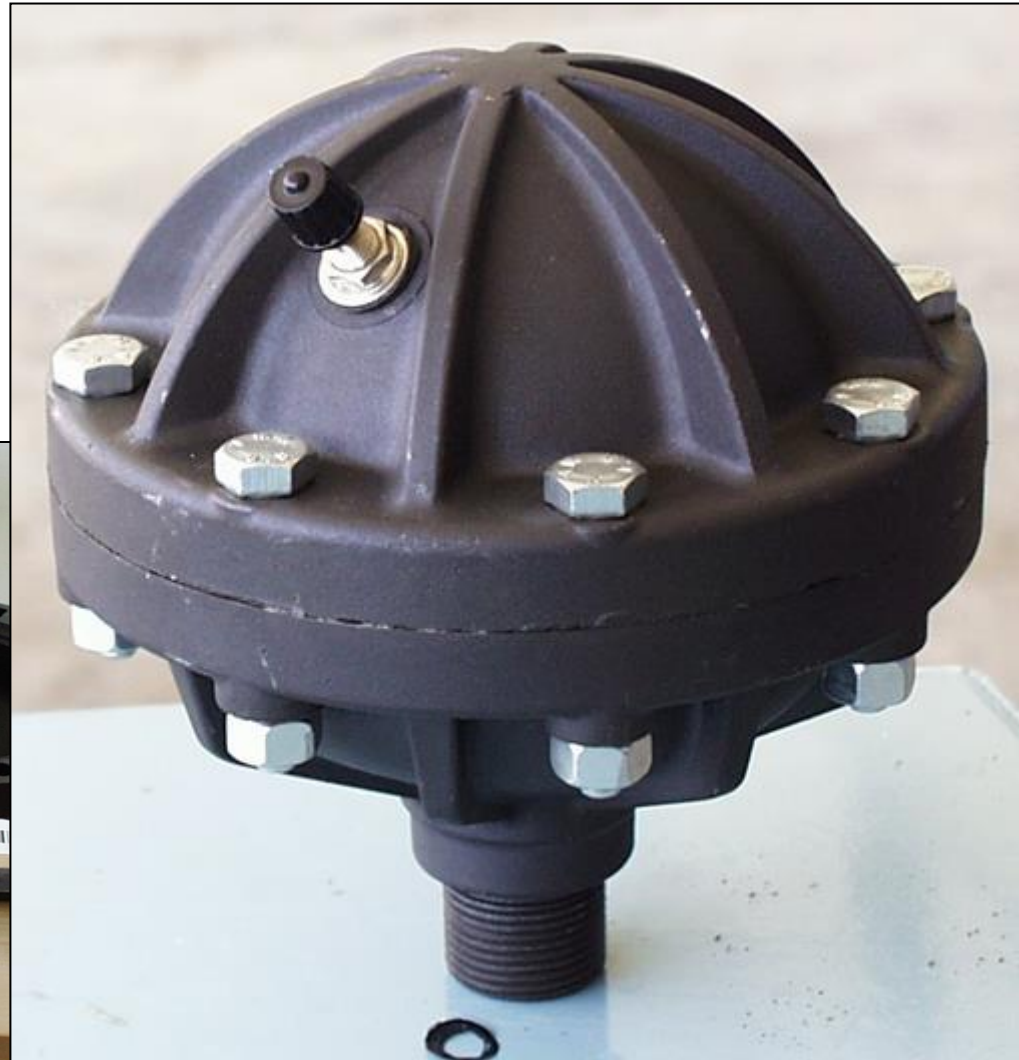

Serbatoio

- Materiale (> polietilene, fibra di vetro, acciaio inox)
- Drenaggio
- Dimensioni apertura principale
- Indicatori di livello
- Sistema di agitazione
- ecc...









Sistema di compensazione della pressione nel serbatoio

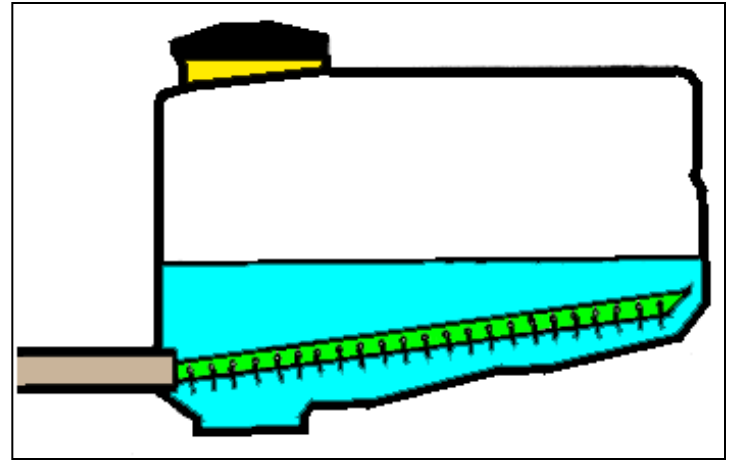
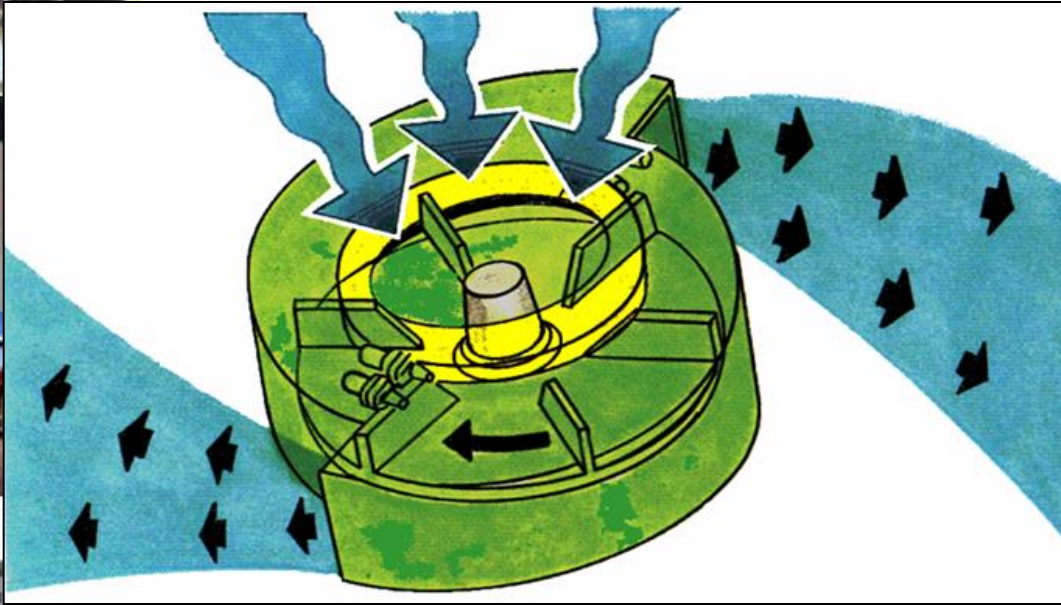





SISTEMI DI RIEMPIMENTO DEL SERBATOIO: IDROINIETTORE



VALVOLA NON-RITORNO

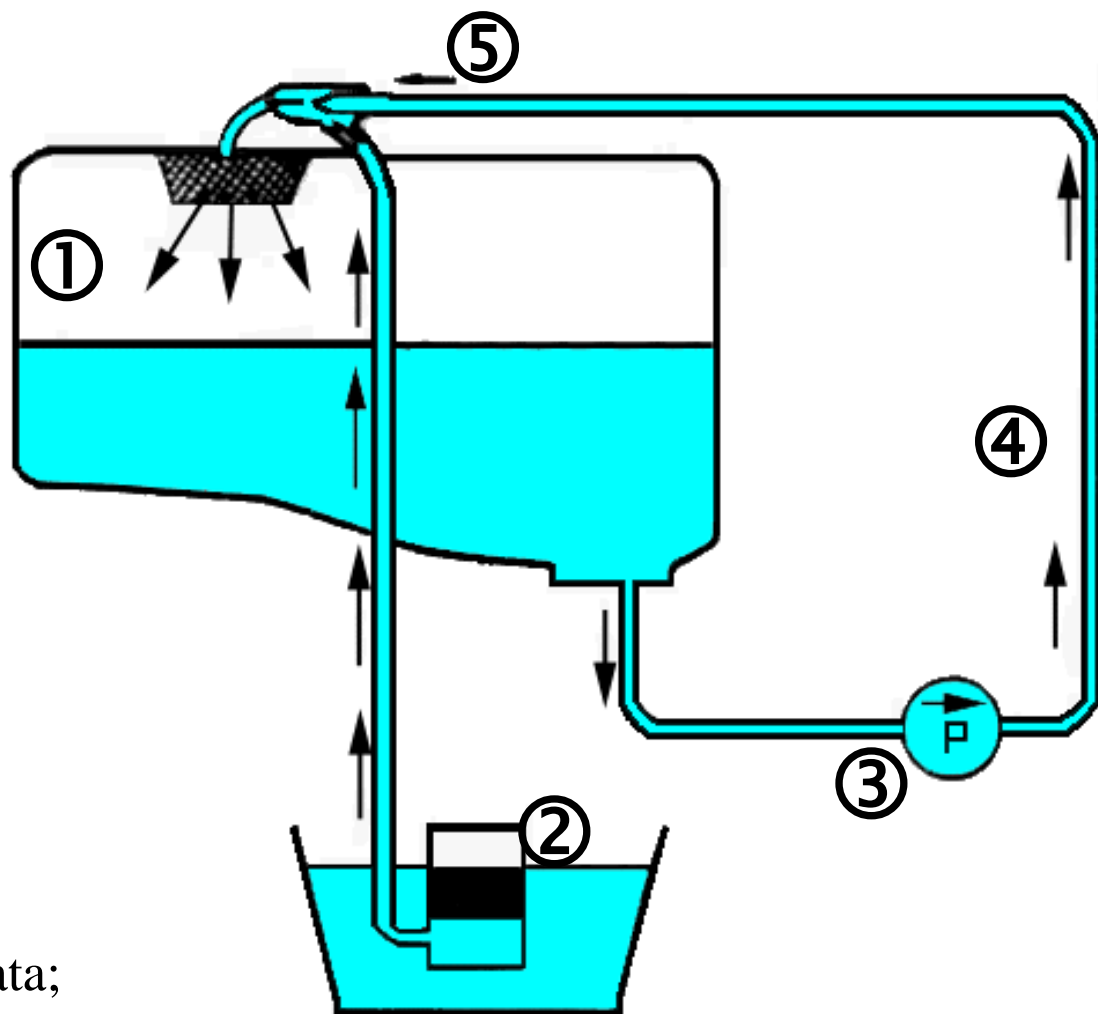

- 1 -Serbatoio;
- 2 -Filtro;
- 3 -Pompa;
- 4 -Circuito di mandata;
- 5 -Tubo venturi.



Serbatoio supplementare in acciaio



Ugello per il lavaggio dei contenitori ubicato nel serbatoio principale

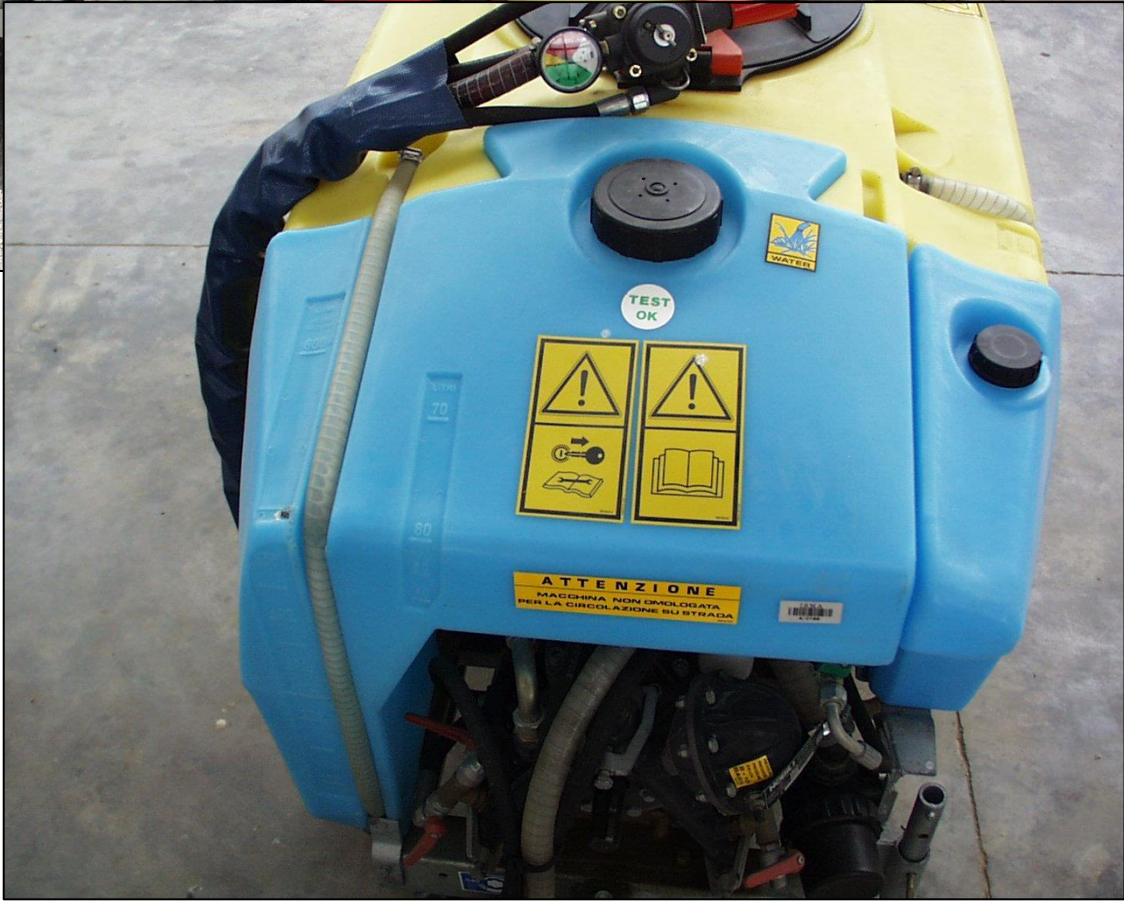

Serbatoi lavaimpianto.

Circa il 10% del serbatoio principale.



Serbatoi lavamani

Serbatoi accessori: premiscelatore





Serbatoi accessori – tracciafile con schiumogeno







Accessori – lancia lavaggio esterno



Sistema di filtrazione

- 1 – Filling device;
- 2 – Tank opening;
- 3 – Before the pump;
- 4 – After the pump;
- 5 – Before distributors (nozzles);

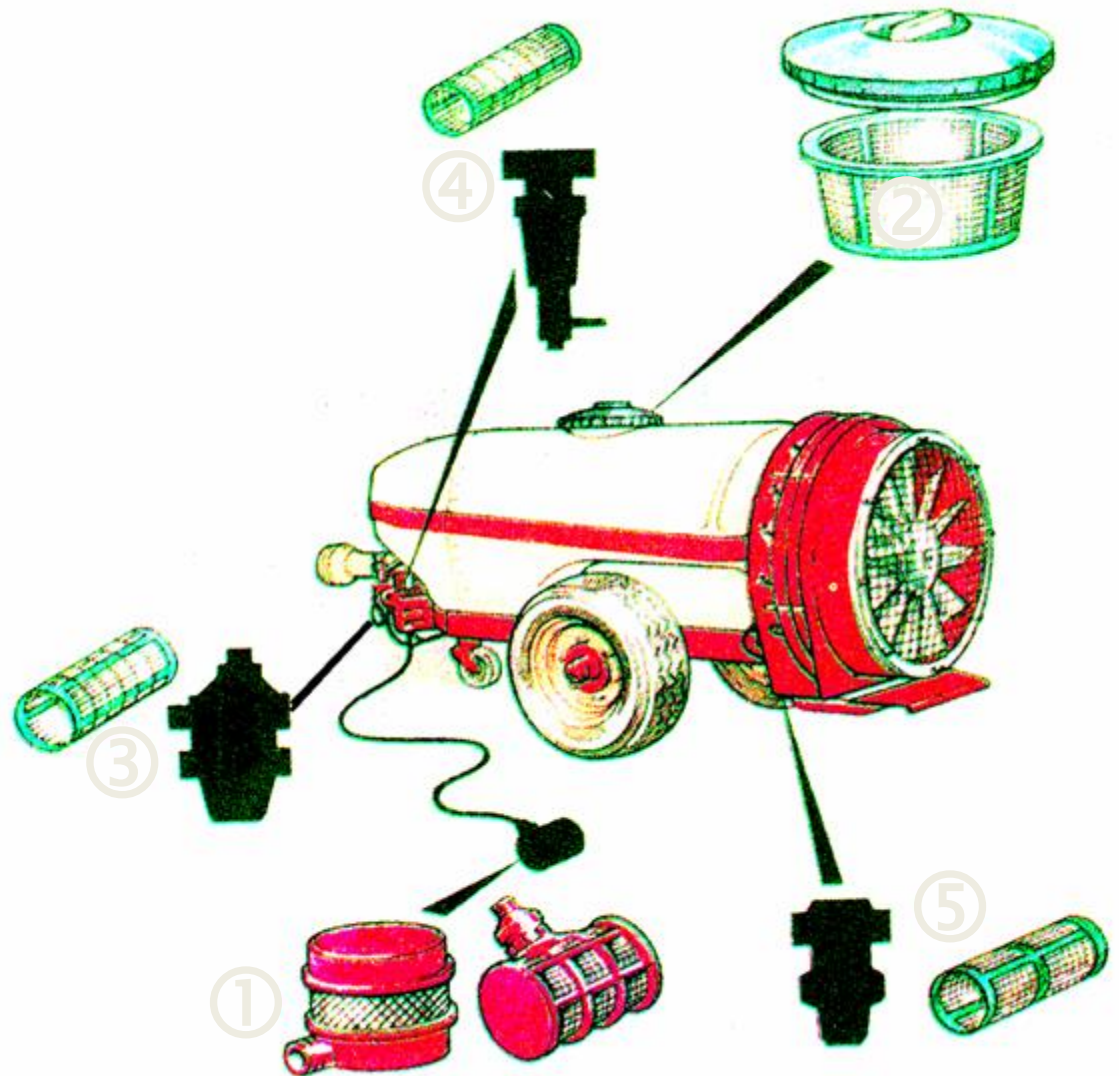



C	MESH	A (microns)	Ø (microns)	S (%)	M
Yellow	16	980	490	44.4	Polypropylene
Yellow	16	1320	220	73.3	Inox
	32	500	320	37.1	Polypropylene
	32	594	200	55.3	Inox
Blue	50	365	140	50.8	Inox
Grey	80	229	80	55.7	Inox
Red	100	173	80	46.4	Inox
Green	120	134	70	43	Poliammide
Green	120	144	70	45.4	Inox
Orange	150	96	65	35	Poliammide
Orange	150	114	60	42.4	Inox
Black	200	80	50	37	Poliammide
Black	200	76	50	36.2	Inox

- C** = colore
MESH = numero di fili per pollice (25,4 mm)
A = apertura utile di passaggio
Ø = diametro del filo
S = rapporto percentuale tra la superficie delle aperture e la superficie totale della rete
M = materiale

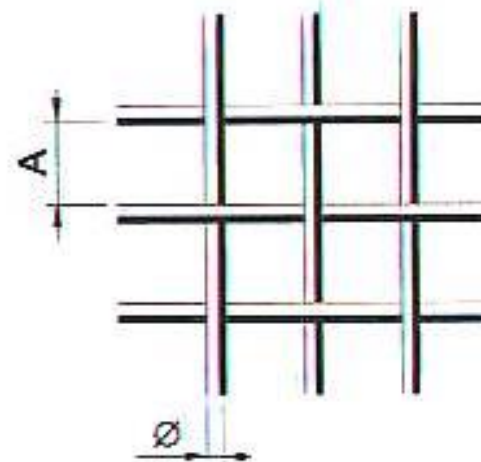

UNITA' DI MISURA = MESH
 (= n° di maglie per pollice)



Sistema di filtrazione

Filtro cestello serbatoio principale

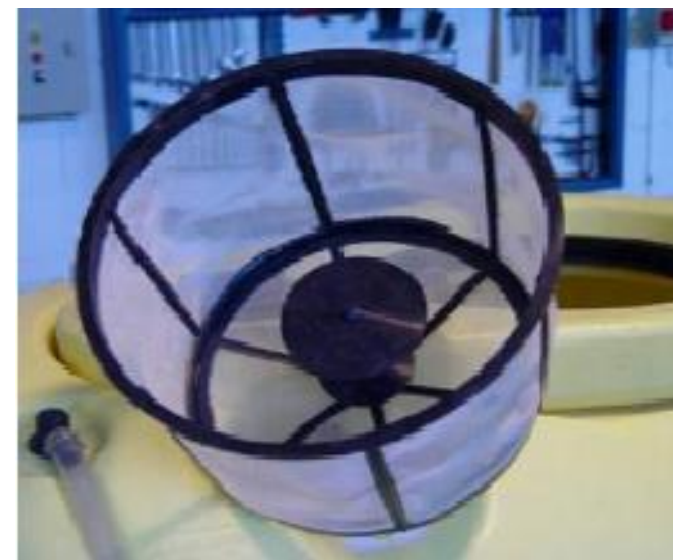

Sistema di filtrazione

Filtro del sistema approvvigionamento



Sistema di filtrazione

Filtro principale

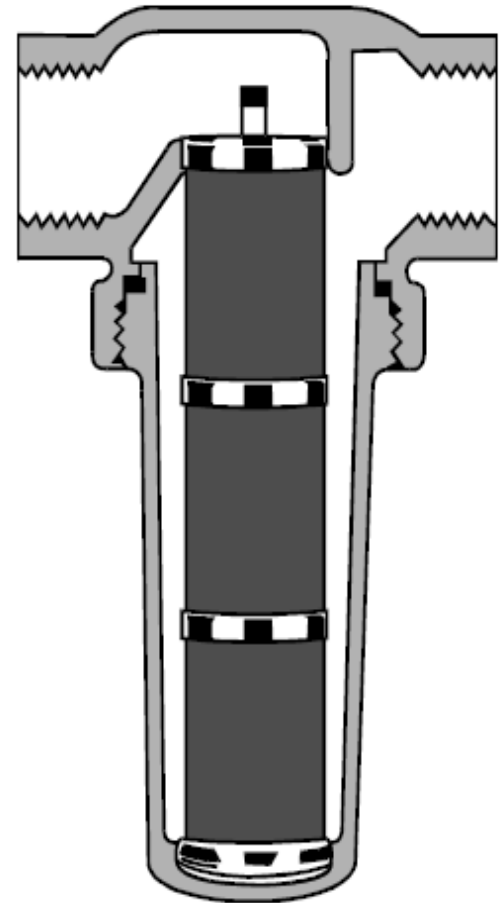

**Sistema
isolamento
filtro
principale**

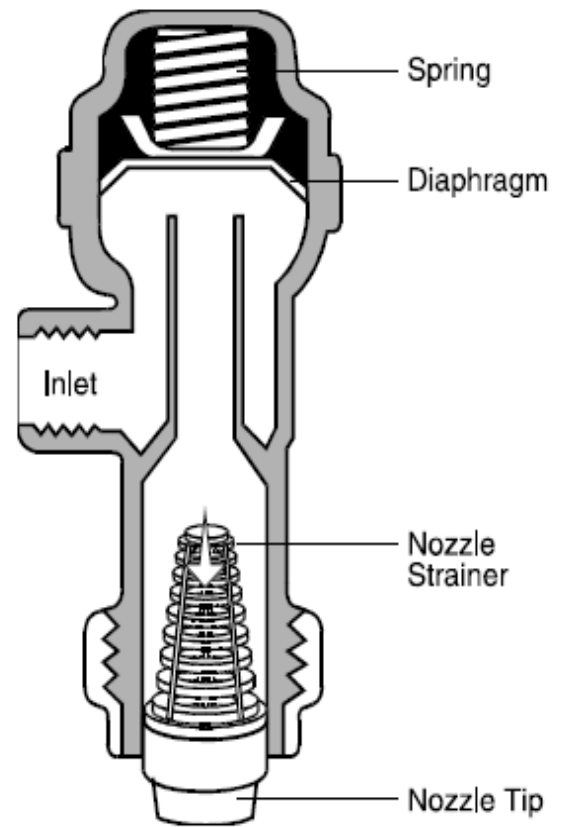







Figure 14. Diaphragm check valve.



Ventilatore

Centrifugo

Assiale





Tangenziale

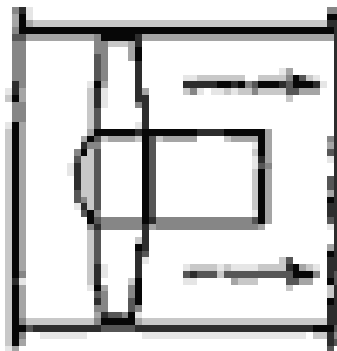

Ventilatori assiali

L'ingresso aria nel ventilatore e la sua uscita seguono un percorso in base alle superfici cilindriche coassiali.

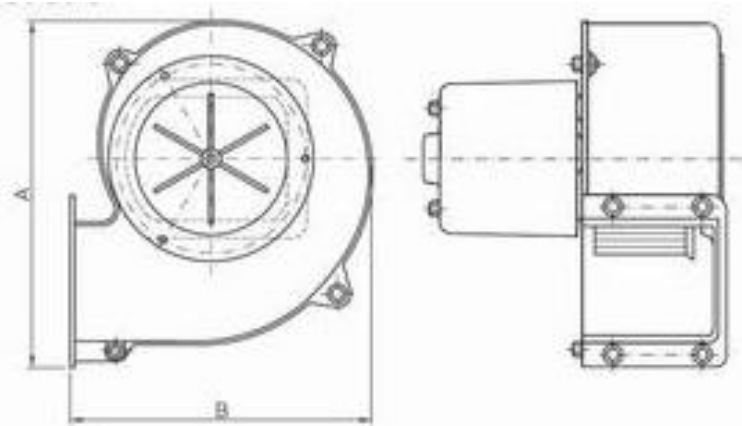

Ventilatori centrifughi

In questi ventilatori il percorso dell'aria segue una direzione assiale all'entrata e parallela a un piano radiale all'uscita. L'entrata e l'uscita sono ad angolo retto.

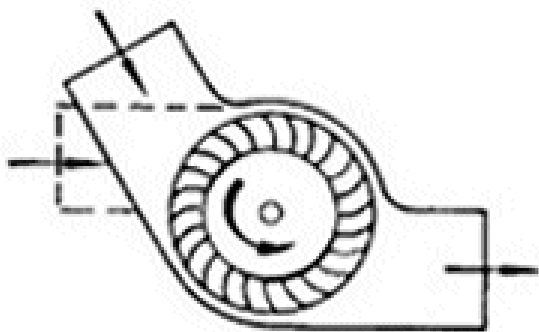

Ventilatori tangenziali

Il percorso dell'aria nella girante di questi ventilatori è normale rispetto all'asse sia all'entrata che all'uscita, e attraversa il corpo dello stesso.



Direzione flusso d'aria di una ventola assiale





Controlli del flusso d'aria

1. Velocità

[m/sec]



Controlli del flusso d'aria

2. Direzione

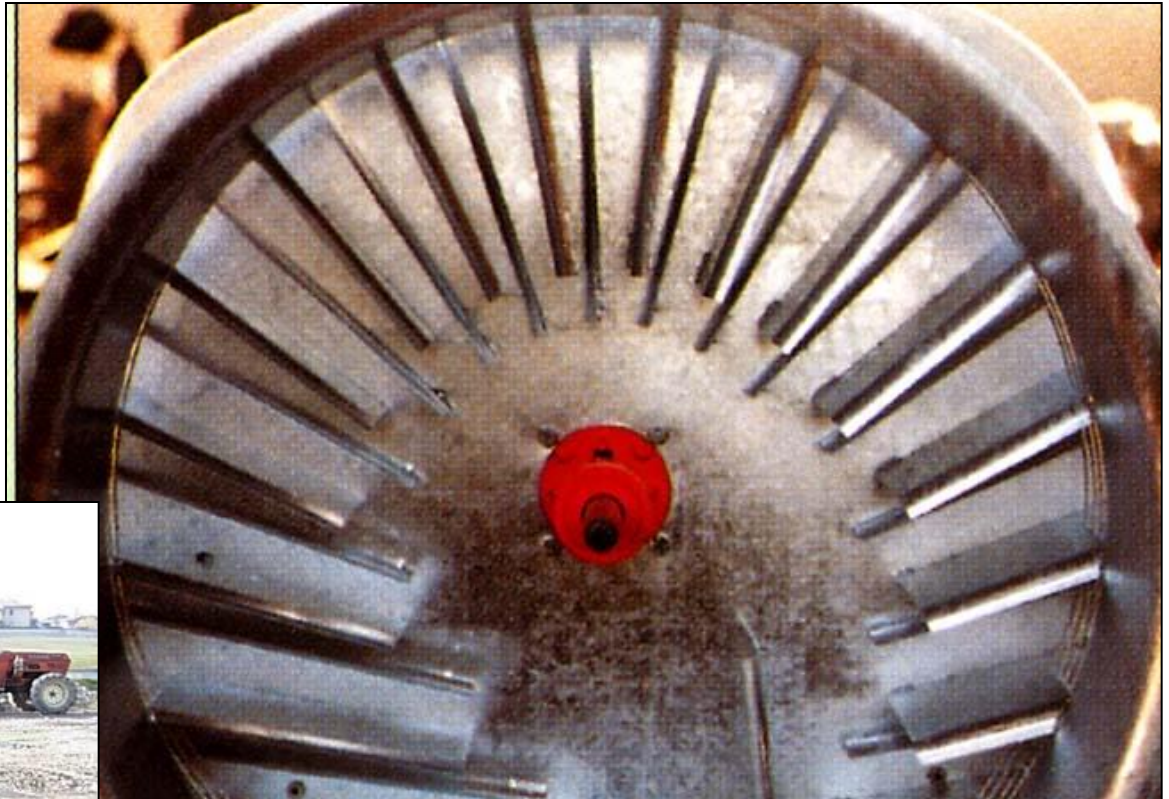

Controlli del flusso d'aria

3. Portata

[m³/h]



Manometro

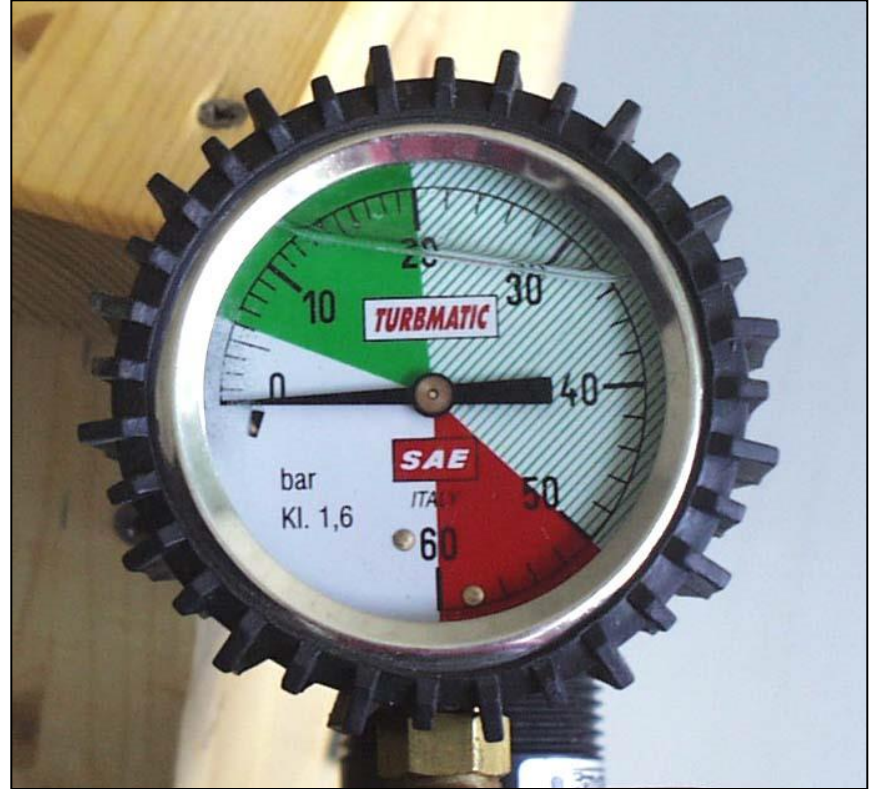



Manometro a molla Bourdon

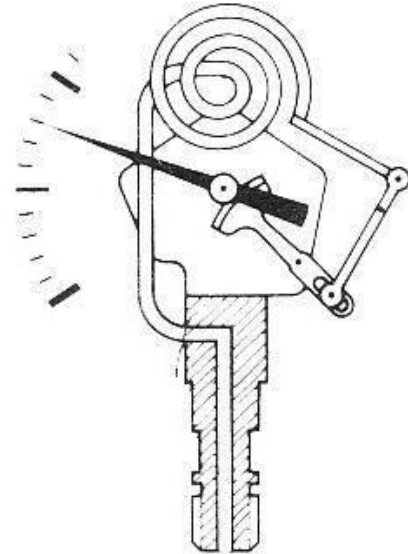
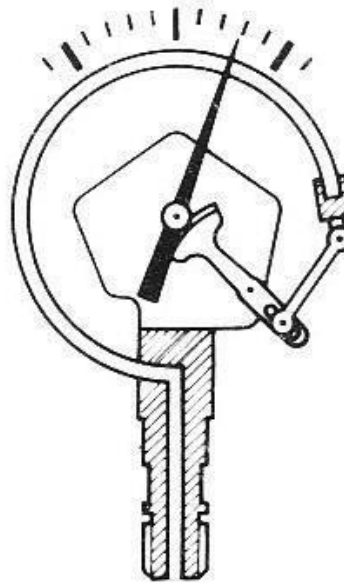



Unità di misura pressione

Pascal	100000	[1 Pa=N/m ²]
Hectopascal	1000	[hPa]
Kilopascal	100	[kPa]
Megapascal	0.1	[MPa]
Bar	1	[bar]
Technical atmosphere	1.0197	[at]
Standard atmosphere	0.9869	[atm]
Torr	750.0638	[Tr]
Millimeters of mercury	750.0638	[mmHg]
Inches of mercury	29.5301	[inHg]
Psi (pound-force per square inch)	14.5038	[lbf/in ²]
Newton per square millimetr	0.1	[1 N/mm ²]
Kilogram per square meter	10197.1621	[1 KG/m ²]

Dimensioni nominali

Le dimensioni nominali (DN) dei manometri sono:
40, 50, 63, 80, 100, 160 e 250

Classi di precisione

La classe di precisione indica i valori limite di errore in percentuale del fondo scala.

Sono definite le seguenti classi di precisione: 0,1, 0,25, 0,6, 1, 1,6, 2,5 e 4.



Assegnazione delle classi di precisione alle dimensioni nominali

Dimensione nominale DN	Classe di precisione						
	0,1	0,25	0,6	1	1,6	2,5	4
40 e 50					X	X	X
63				X	X	X	X
80				X	X	X	X
100				X	X	X	
160		X	X	X	X		
250	X	X	X	X	X		

A una temperatura di riferimento di 20 °C l'errore totale di indicazione del manometro non deve superare i valori indicati nella seguente tabella.

Classe di precisione	Valori limite di errore (percentuale del fondo scala)
0,1	± 0,1 %
0,25	± 0,25 %
0,6	± 0,6 %
1	± 1 %
1,6	± 1,6 %
2,5	± 2,5 %
4	± 4 %

Scala di lettura



Intervallo 2 bar

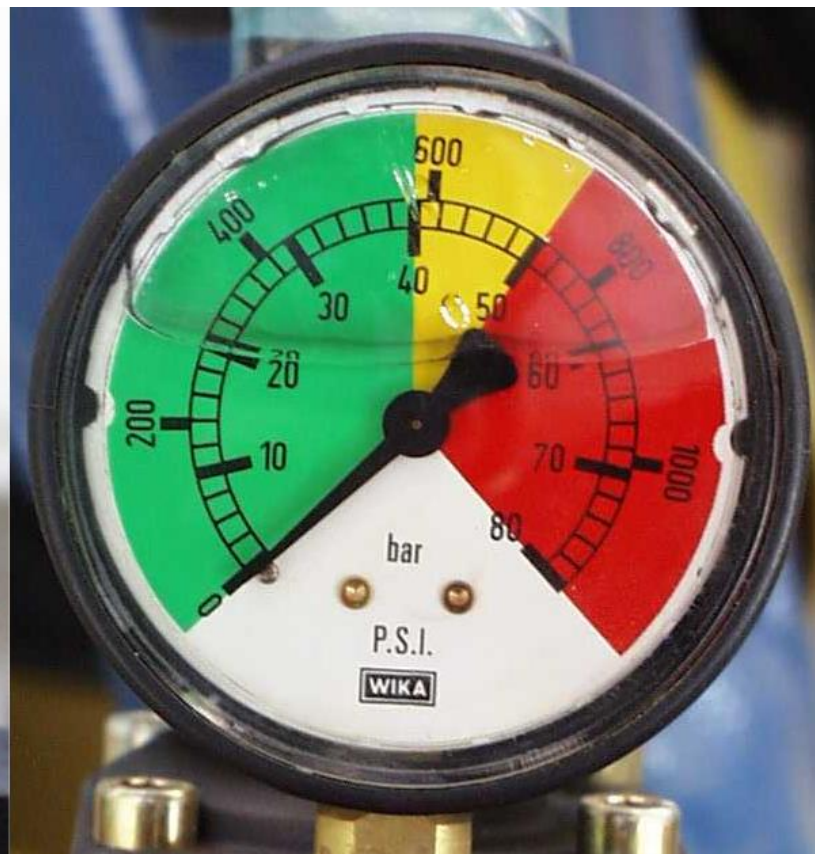

Intervallo 2,5 bar



Intervallo 0,2 bar



Intervallo 0,5 bar



La scala deve avere un intervallo di lettura $\leq a$:



- 0,2 bar per pressioni di lavoro ≤ 5 bar;
- 1,0 bar per pressioni di lavoro comprese tra 5 e 20 bar;
- 2,0 bar per pressioni di lavoro ≥ 20 bar.



Sistemi di controllo portata1

PC, a pressione costante



TERRENO	SALITA	DISCESA	SLITTAMENTO
GIRI MOTORE			
VELOCITA' DI AVANZAMENTO			
PORTATA l/min			
VOLUME ETTARO			
RISULTATI	SOVRADOSAGGIO	SOTTODOSAGGIO	SOVRADOSAGGIO



SCHEMA COSTRUTTIVO DI UN SISTEMA DI REGOLAZIONE A PRESSIONE COSTANTE (PC)

- 1 -Regolatore di pressione;
- 2 -Manometro;
- 3 -Pompa;
- 4 -Serbatoio;
- 5 -Organi di distribuzione;
- 6 -Ritorno del liquido.

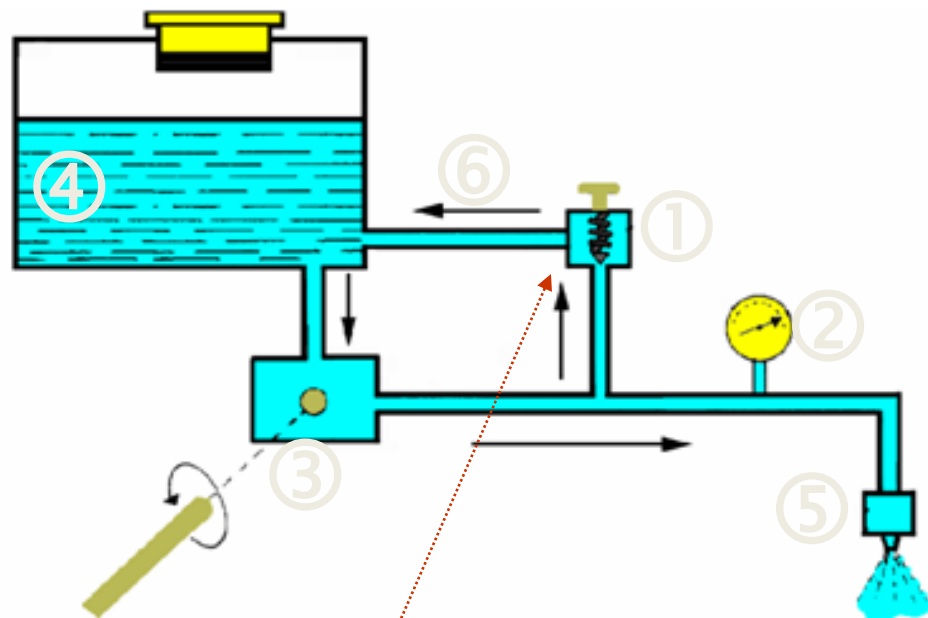

Particolare del regolatore:

- 1 -Liquido in pressione;
- 2 -Molla;
- 3 -Regolatore della molla;
- 4 -Liquido di ritorno al serbatoio;
- 5 -Liquido inviato agli organi di distribuzione;

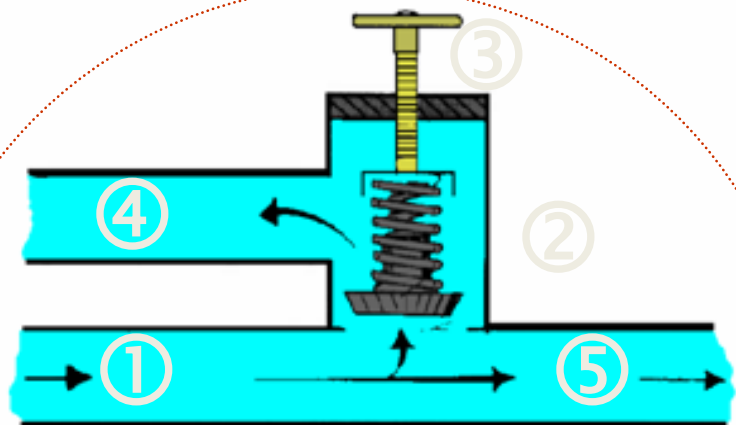

REGOLATORE DI PRESSIONE

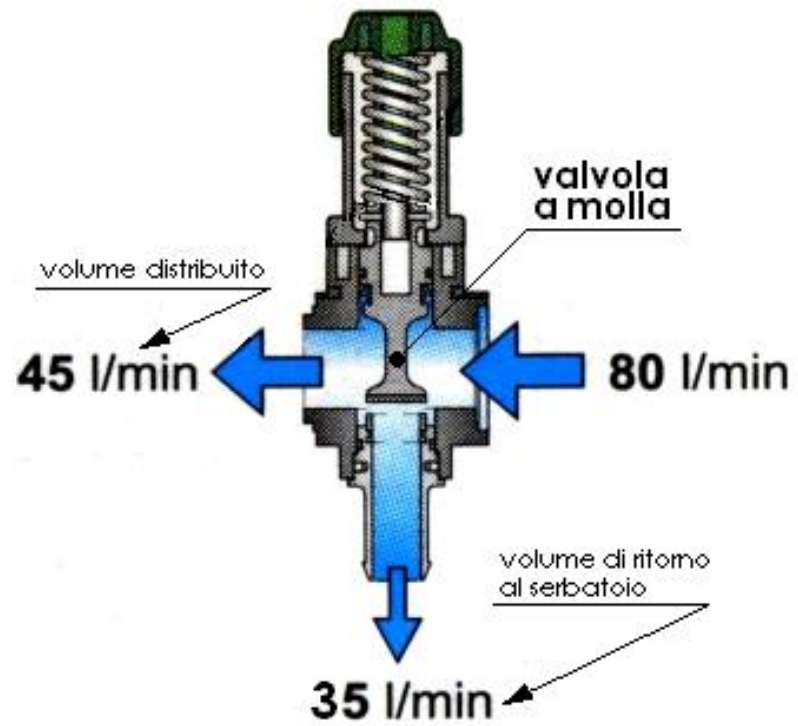

Controllo portata 2

Dose proporzionale al regime del motore DPM



TERRENO	SALITA	DISCESA	SLITTAMENTO
GIRI MOTORE			
VELOCITA' DI AVANZAMENTO			
PORTATA l/min			
VOLUME ETTARO			
RISULTATI	GIUSTA DOSE	GIUSTA DOSE	SOVRADOSAGGIO



valvola di regolazione proporzionale

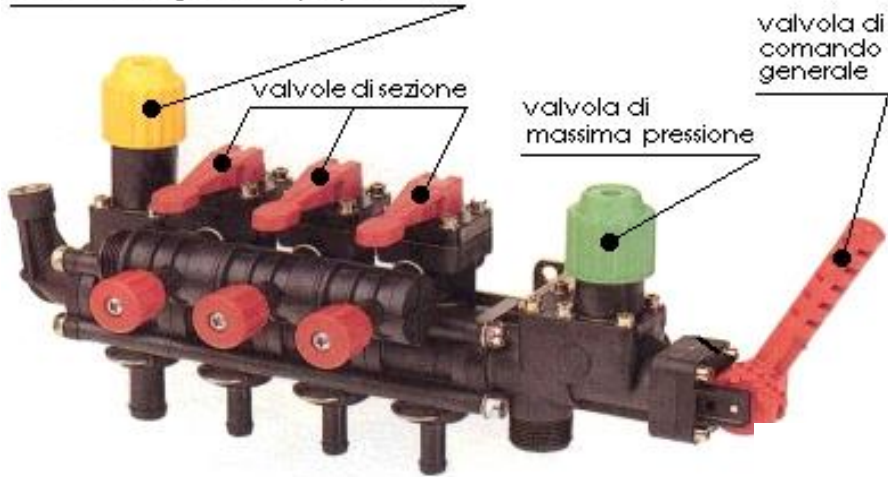

servomeccanismo elettrico di controllo

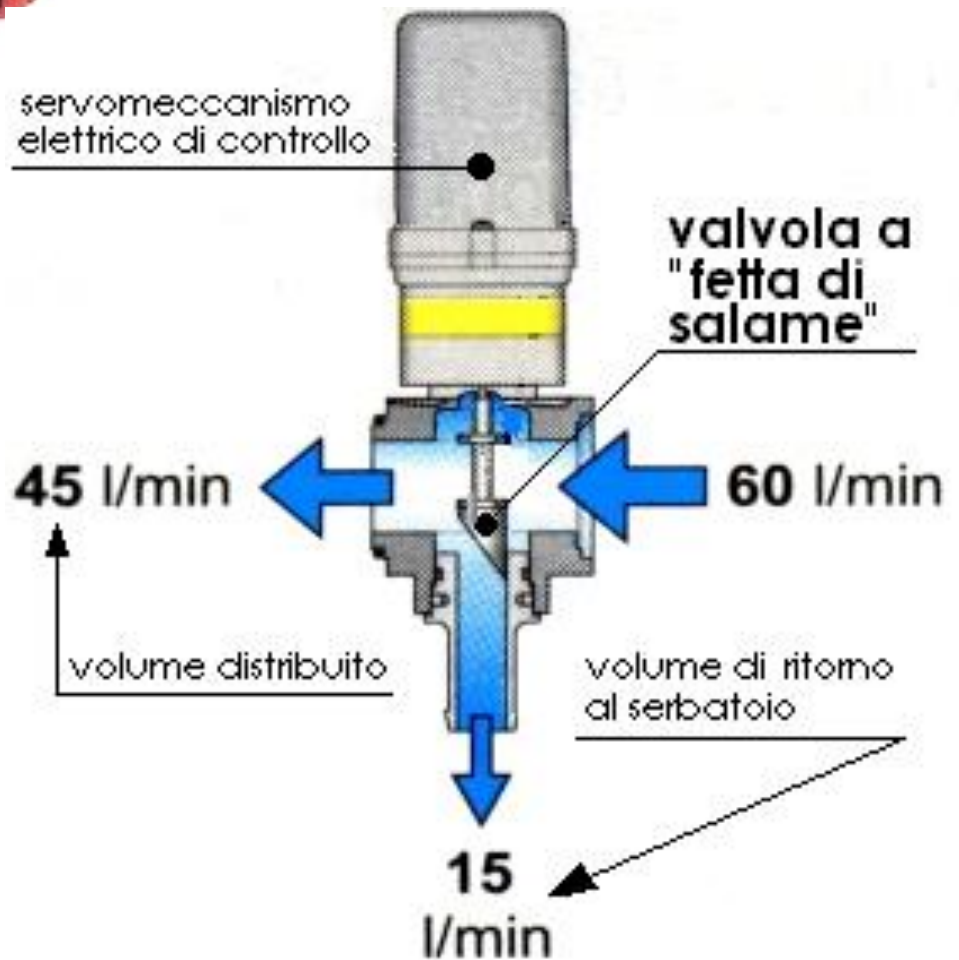

Flow control 3

Proporzionale alla velocità d'avanzamento DPA



TERRENO	SALITA	DISCESA	SLITTAMENTO
GIRI MOTORE			
VELOCITA' DI AVANZAMENTO			
PORTATA l/min			
VOLUME ETTARO			
RISULTATI	GIUSTA DOSE	GIUSTA DOSE	GIUSTA DOSE



DPA con ruotino ausiliario



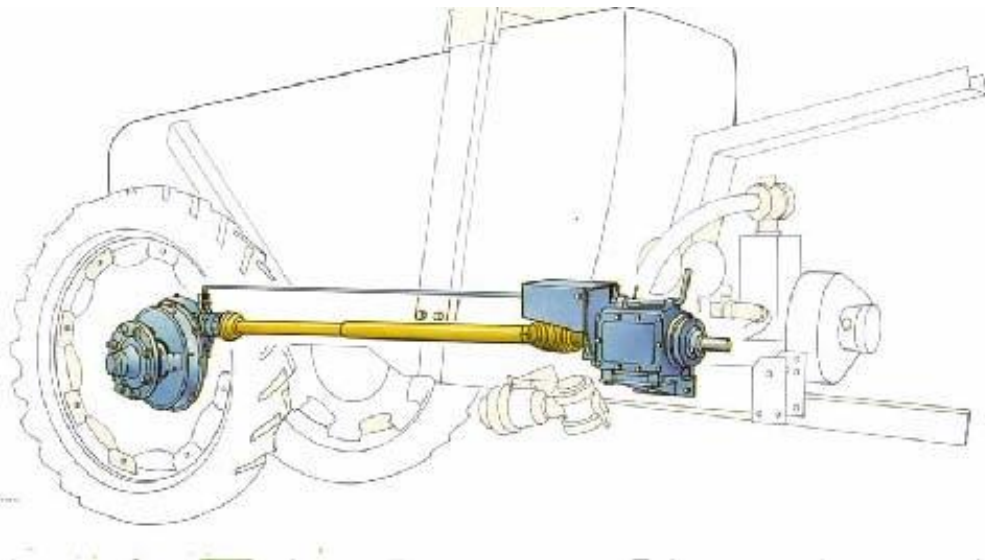

Sistemi di regolazione della dose 4

Sistema proporzionale alla concentrazione CPA

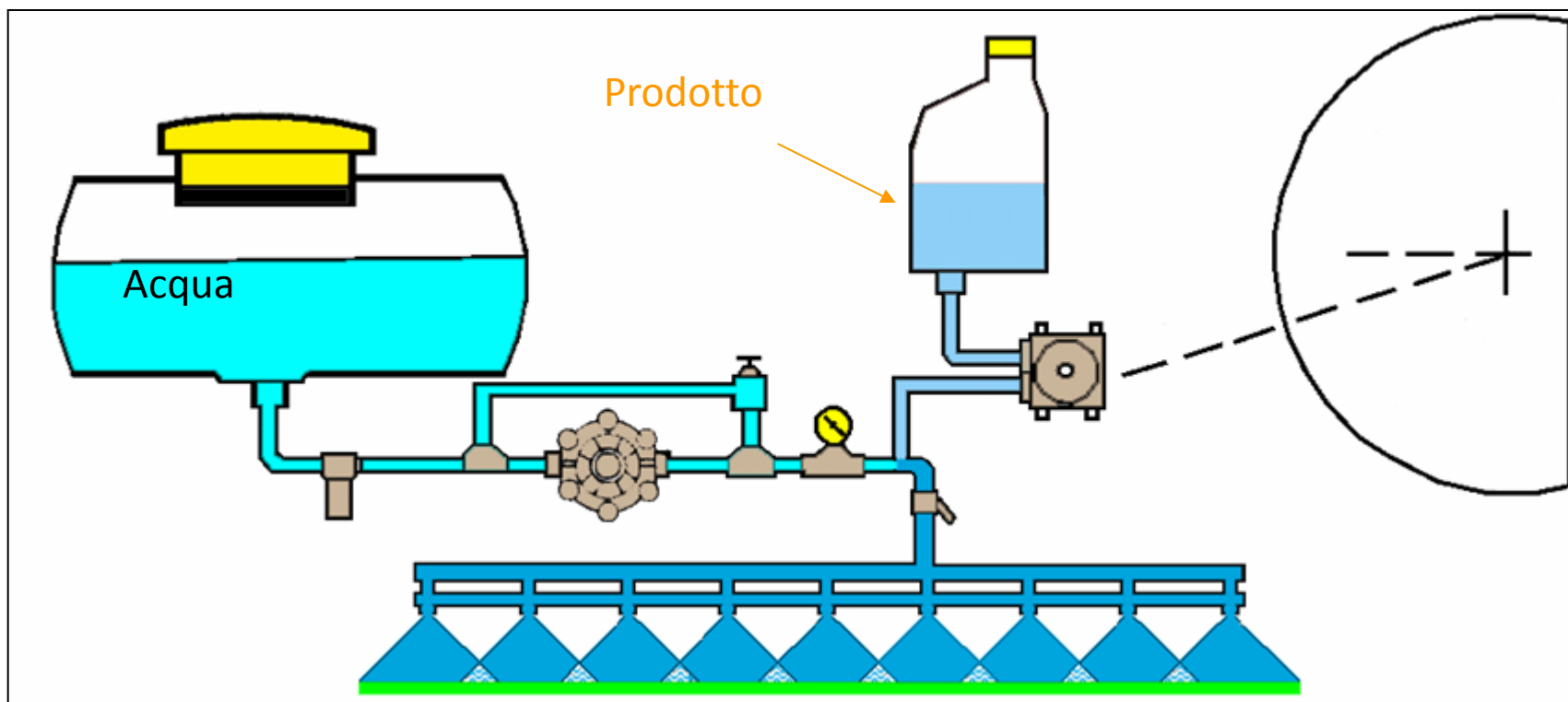

Sistemi di regolazione e controllo





Sistemi di regolazione e controllo

Ugelli



MATERIALI

Materiale		Caratteristiche
	Ceramica	durata estremamente lunga alta resistenza a prodotti chimici abrasivi e corrosivi
	Acciaio inossidabile temprato	durata molto lunga buona resistenza all'usura e ai prodotti chimici
	Acciaio inossidabile	durata lunga eccellente resistenza ai prodotti chimici e buona all'usura
	Polimero	durata da media a lunga buona resistenza ai prodotti chimici possibilità di danneggiare l'orefizio durante la pulizia
	Ottone	durata breve possibilità di corrosione specialmente con fertilizzanti



Durata ugelli

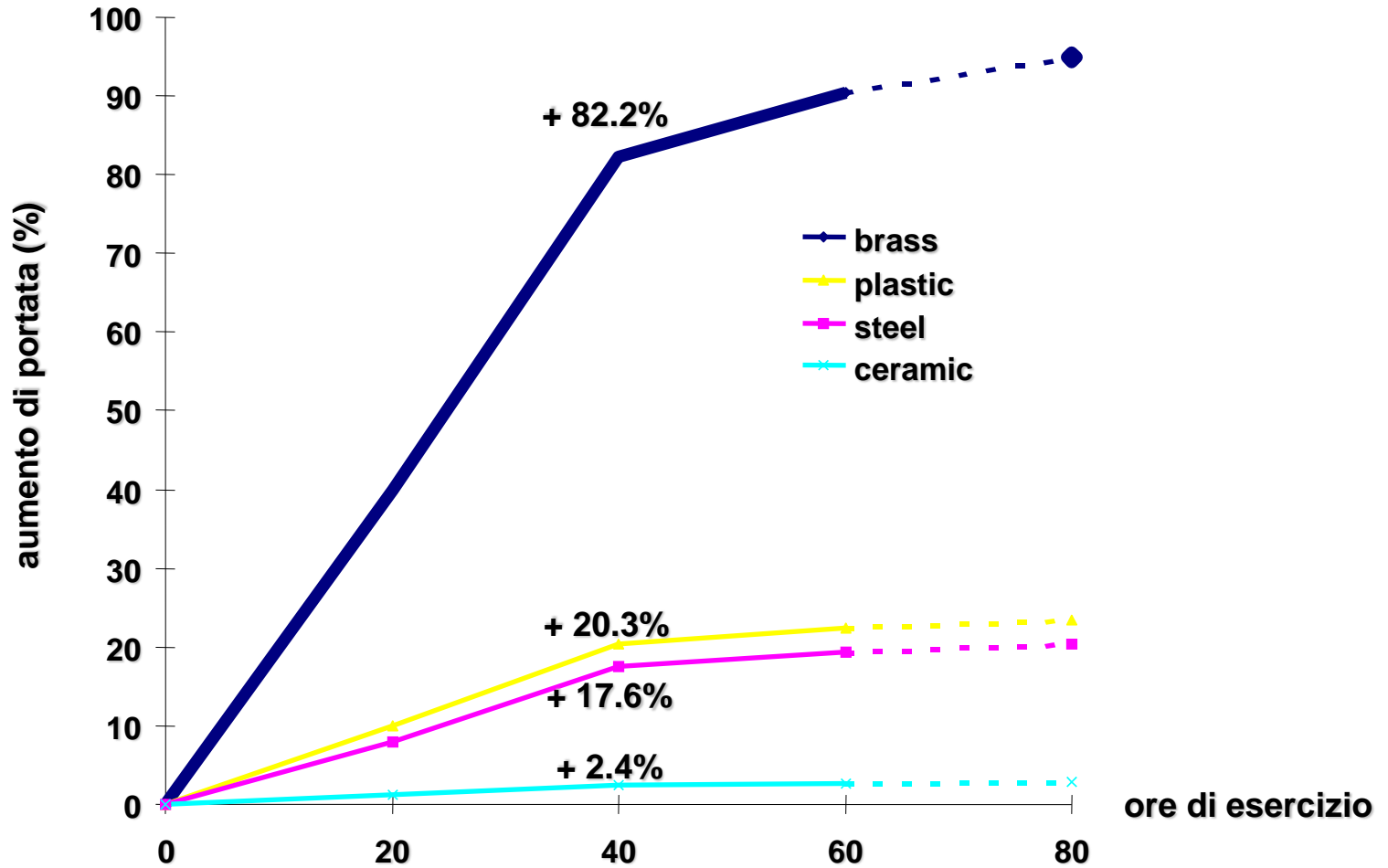

UGELLI: CODICE

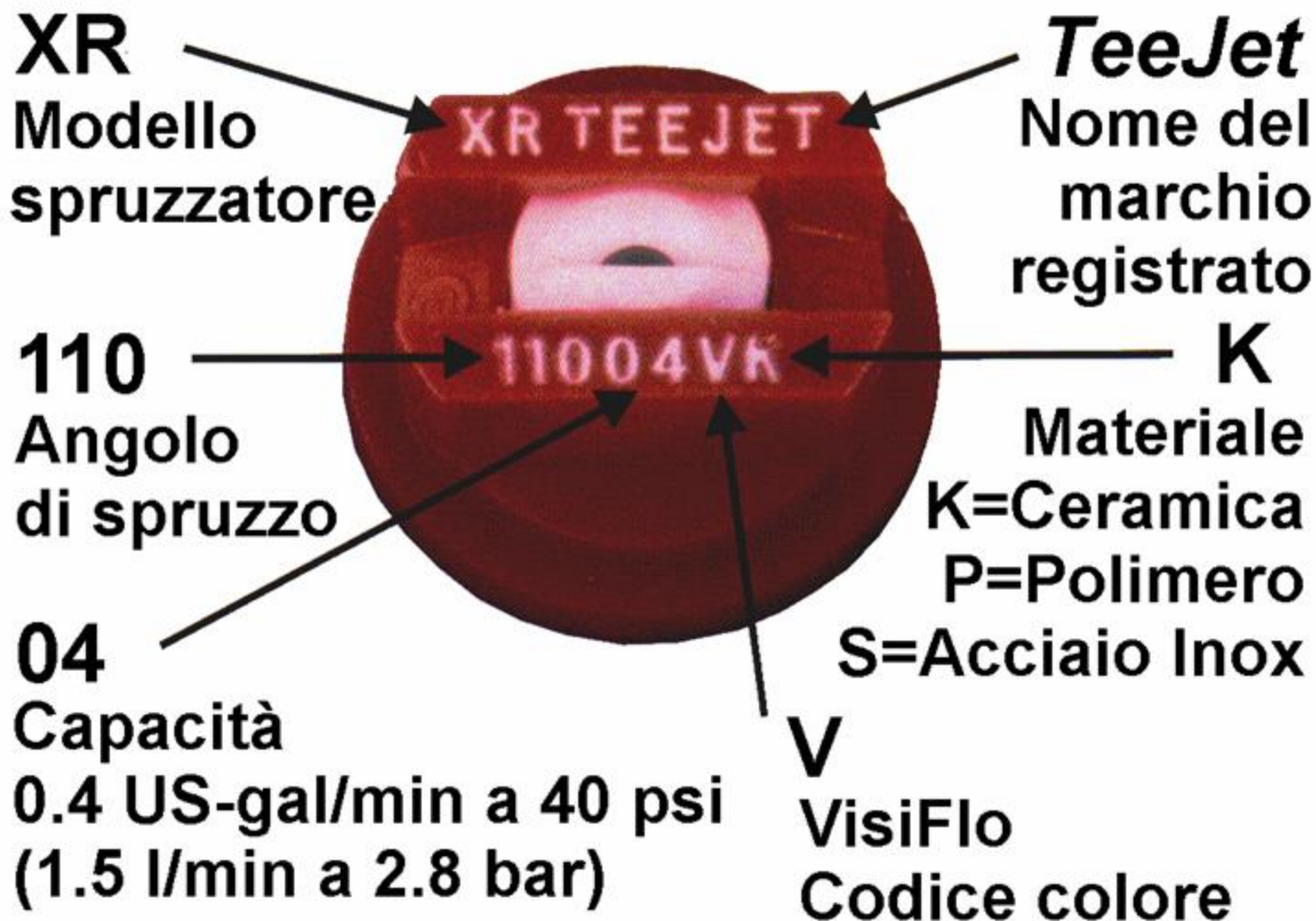

Ugello a ventaglio

[> Catalogo](#)

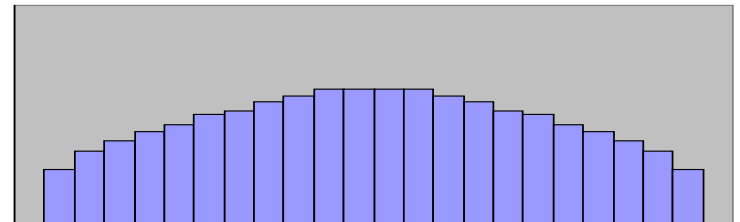
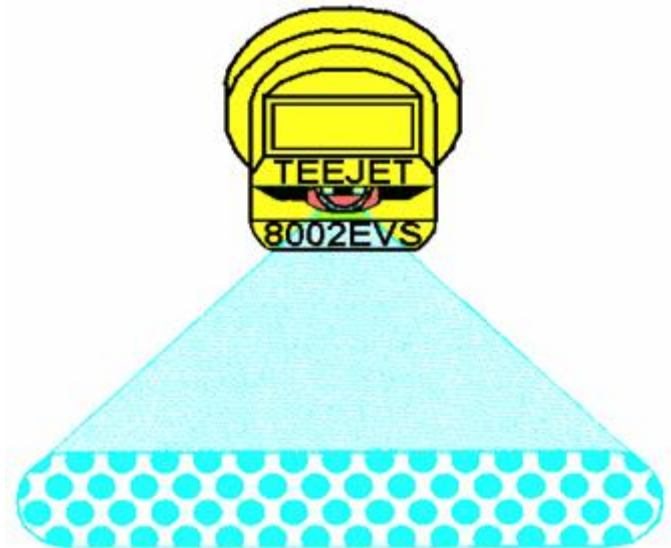
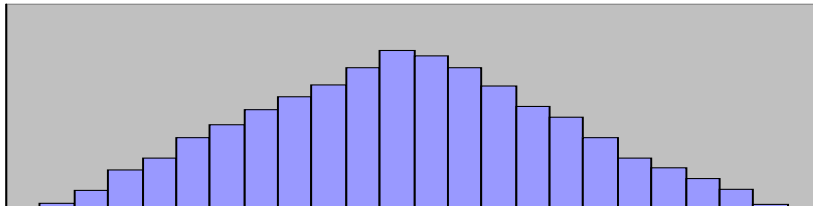
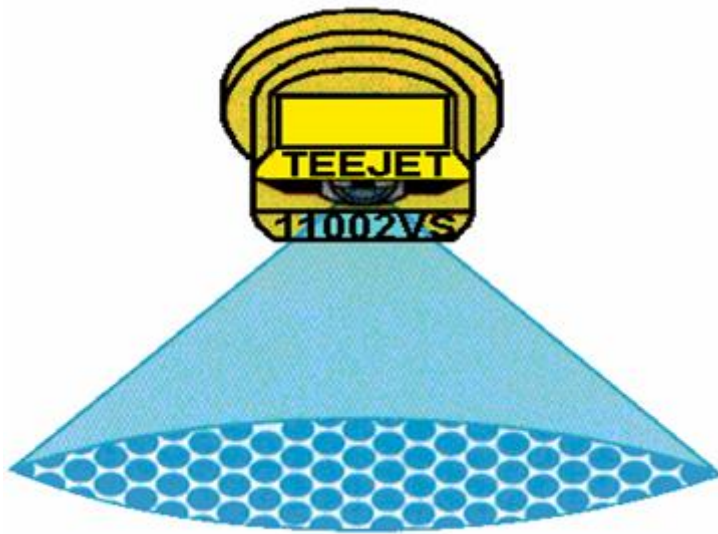

da catalogo TEEJET

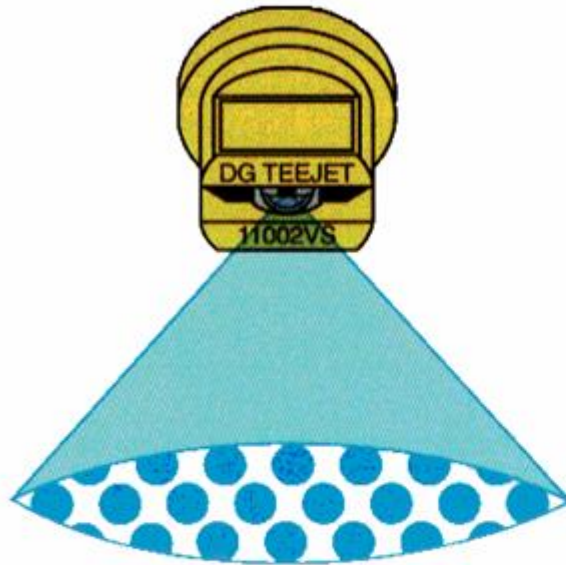

Gocce grosse
PRESSIONE 2,0 - 4,0 bar

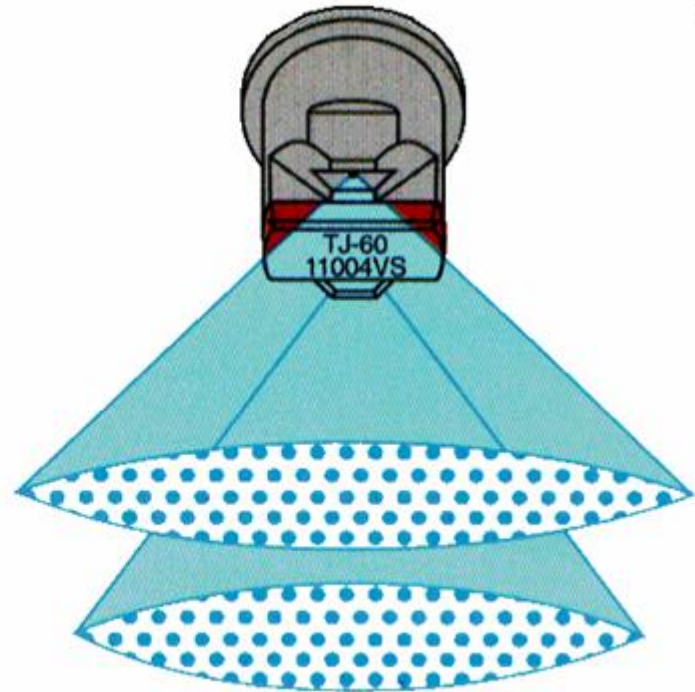

Doppio ventaglio
(penetrazione nella vegetazione)
2.0-4.0 bar

da catalogo TEEJET

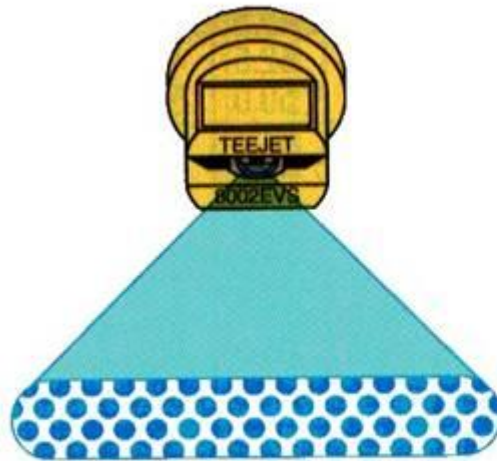

**Per spruzzatura a bande sulle file
o nell'interfilare;
pressione d'esercizio 1.5-3 bar**

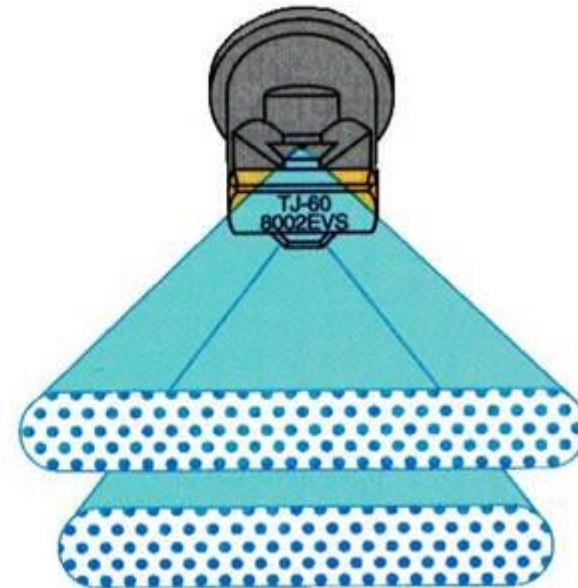

**per spruzzatura a bande sulle file o
nell'interfilare;
gocce più piccole per una copertura più
intensiva; pressione d'esercizio 2-4 bar**

da catalogo TEEJET

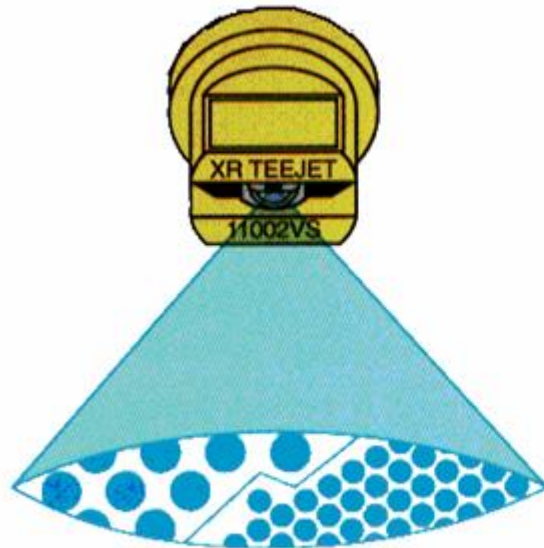

1 bar

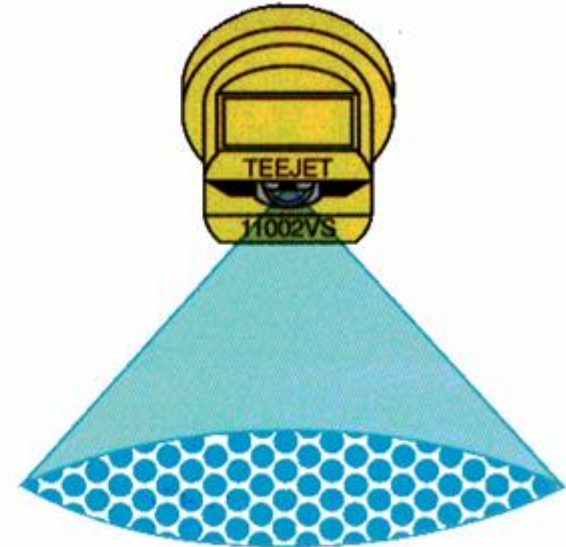

4 bar

Gocce grosse con bassa deriva a bassa pressione; gocce più piccole ad alte pressioni, con copertura più uniforme.

buona penetrazione con copertura uniforme a pressioni di 2 - 4 bar

Componenti

Getto a cono

Doppio corpo

Ugello a turbolenza

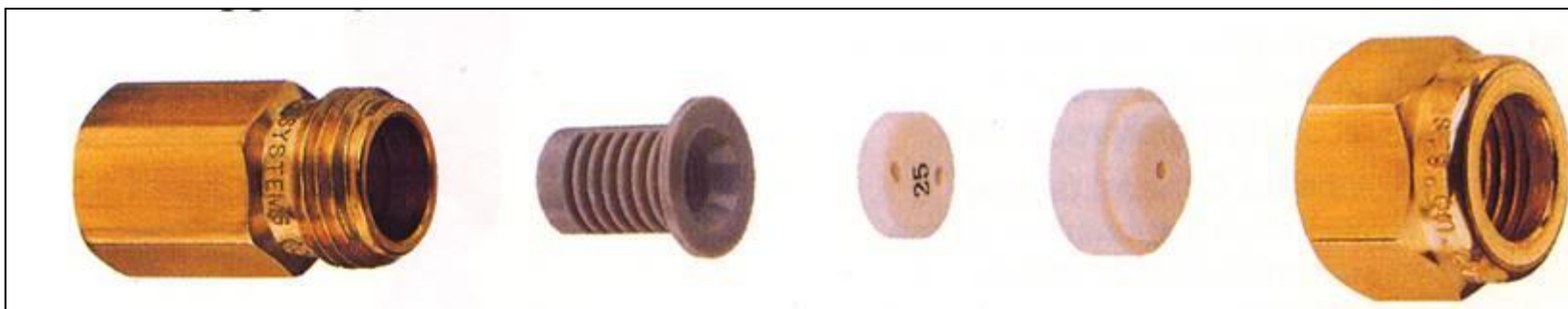
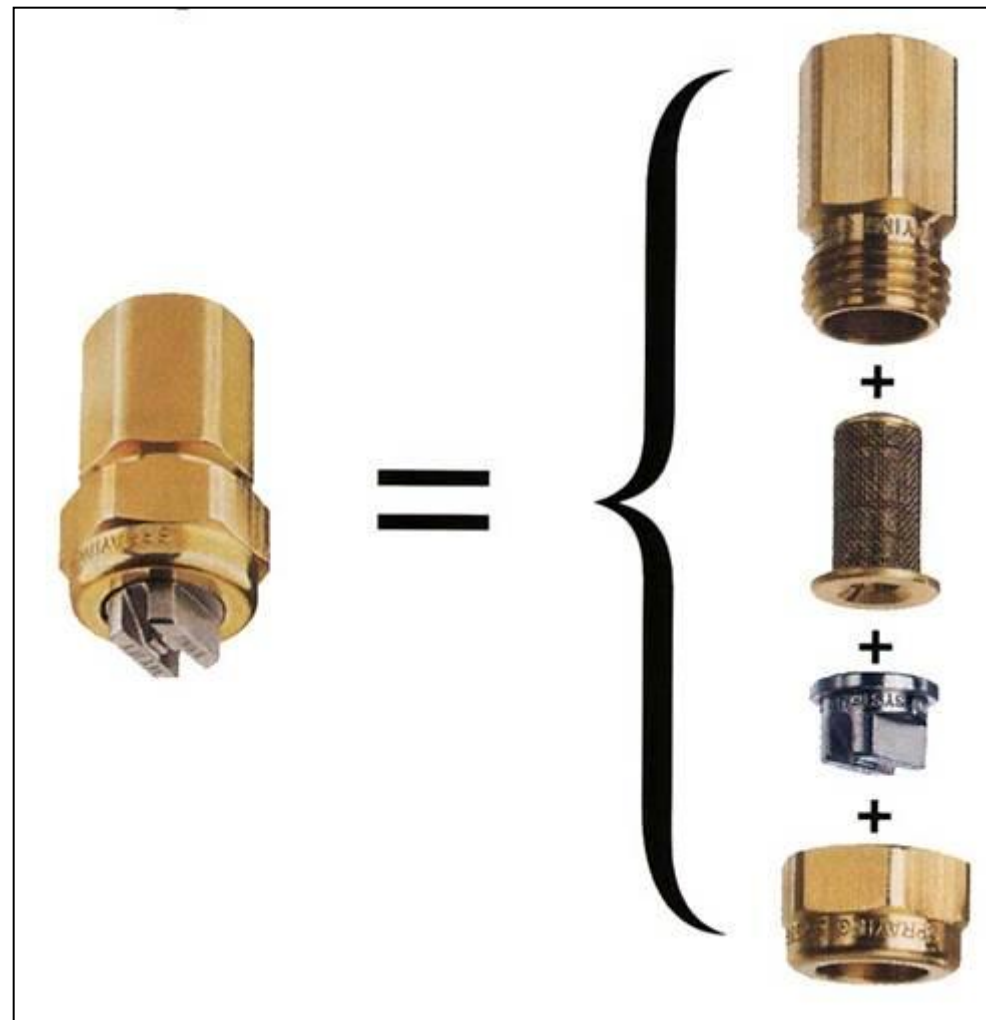

Ugello a cono a doppio corpo

Piastrine



Ceramica



**Acciaio inox
temprato**



Alluminio



Ottone



Nylon

Dischi



Ceramica



**Acciaio inox
temprato**



Acciaio inox



Polimero

da catalogo TEEJET

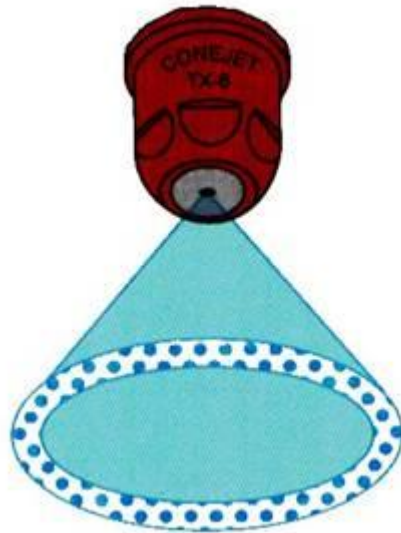

CONO VUOTO

per spruzzatura a bande
gocce più piccole per
erbicidi e insetticidi;
pressione d'esercizio 3-4 bar

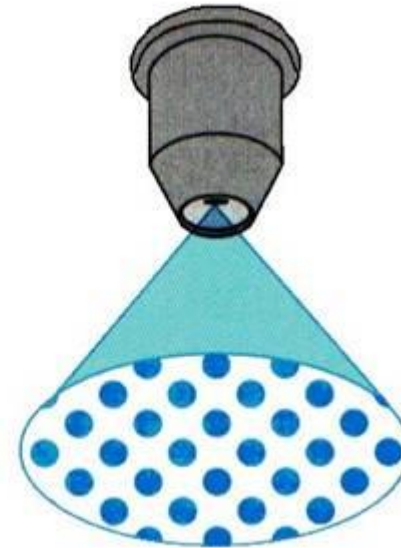

CONO PIENO

buona penetrazione gocce più
grandi eccellente per fitoregolatori
uso tipico di tre per fila pressione 3-
5,5 bar



Ugello a cono schema

- 1 -Raccordo con la tubazione;
- 2 -Ghiera di ancoraggio al raccordo;
- 3 -Filtro;
- 4 -Elica ;
- 5 -Canale dell'elica;
- 6 -Camera di turbolenza;
- 7 -Piastrina.

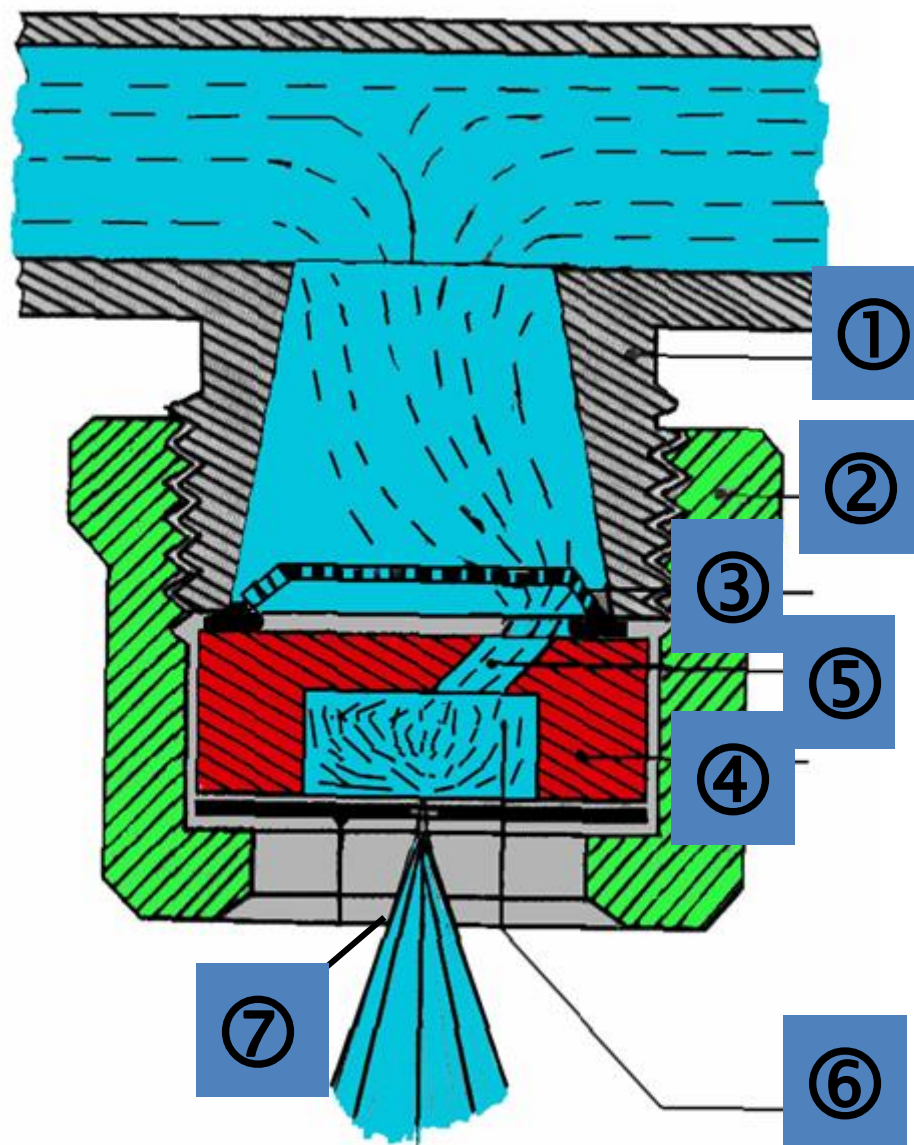

Ugelli a cono

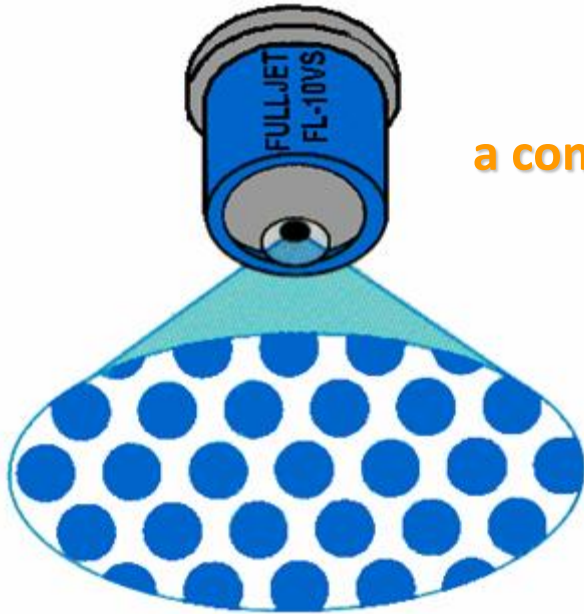

a cono pieno

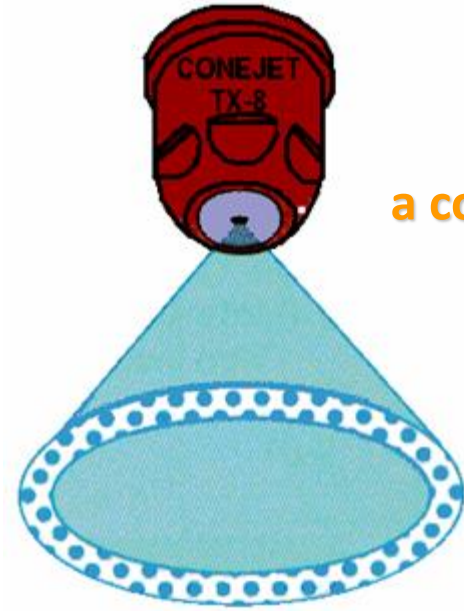

a cono vuoto

Fonte Teejet

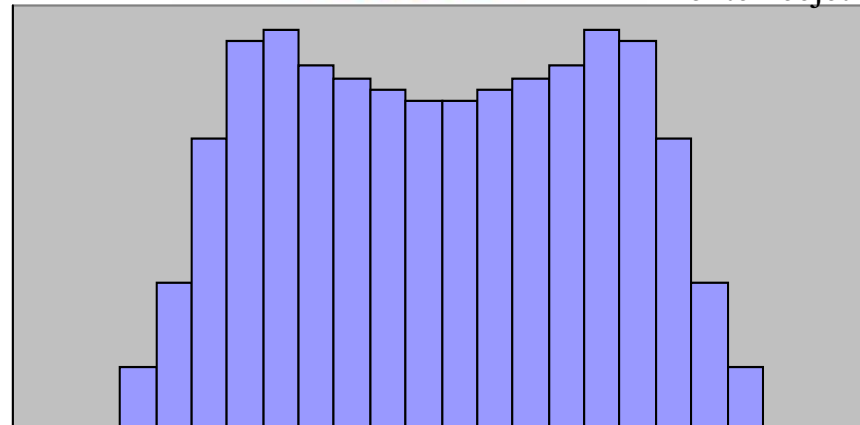
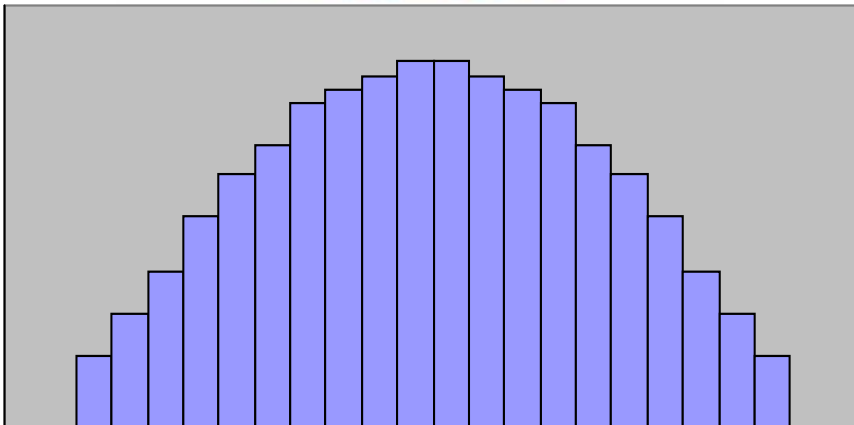

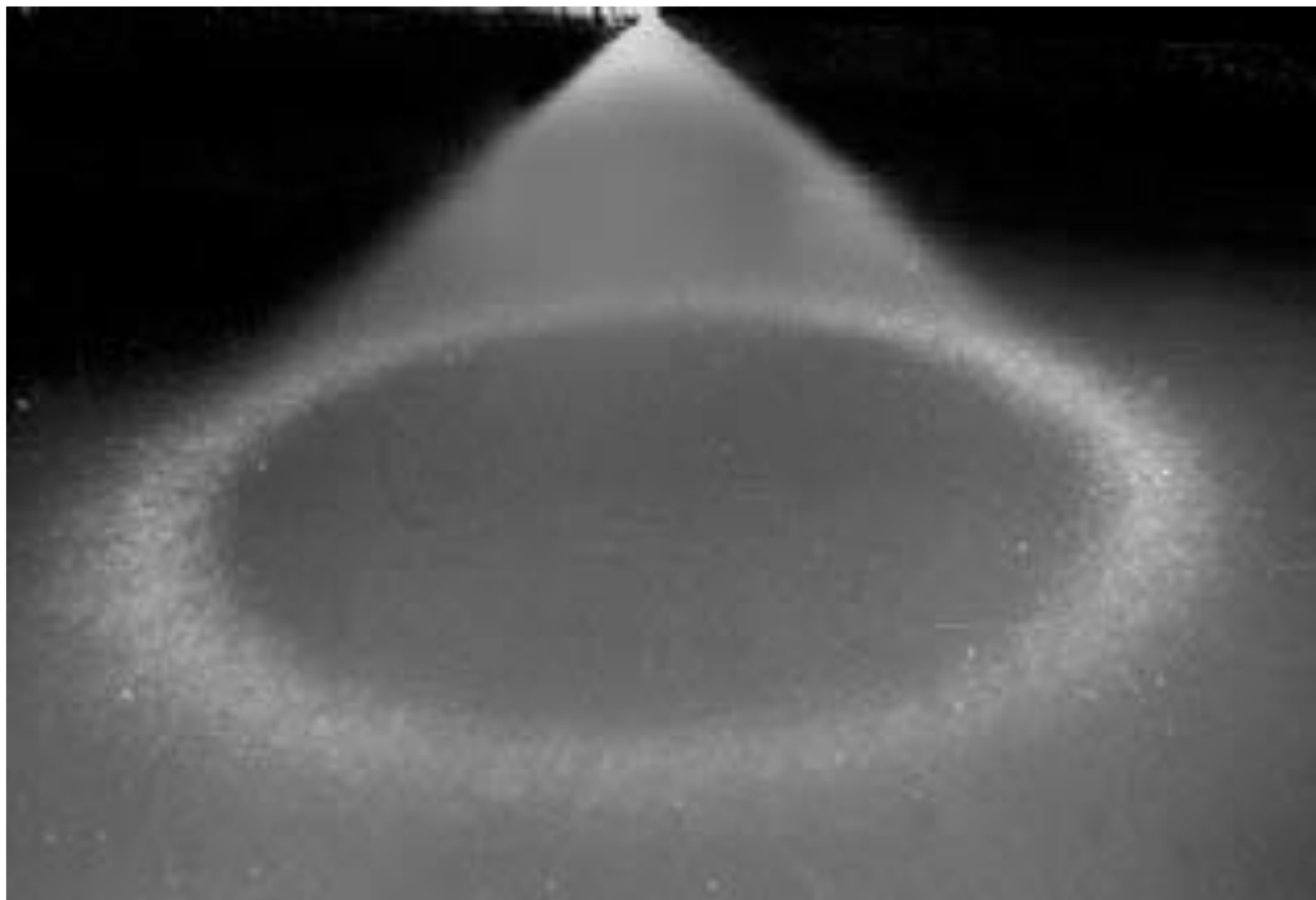

Corno vuoto

ALBUZ NOZZLES

PRESSIONE		PORTATA lt/min								
BAR	PSI	423203	423204	423205	423206	423207	423208	423209	423210	423211
1	15	0,35	0,49	0,70	0,99	1,40	1,97	2,79	3,97	5,60
1,2	17	0,38	0,54	0,77	1,03	1,53	2,16	3,06	4,35	6,13
1,4	20	0,41	0,58	0,83	1,17	1,65	2,34	3,31	4,70	6,63
1,6	23	0,44	0,62	0,88	1,25	1,77	2,50	3,53	5,02	7,08
1,8	26	0,47	0,66	0,93	1,32	1,88	2,65	3,74	5,32	7,50
2	29	0,49	0,70	0,99	1,40	1,98	2,79	3,95	5,62	7,92
2,2	32	0,52	0,73	1,03	1,46	2,07	2,93	4,14	5,89	8,31
2,4	35	0,54	0,76	1,04	1,53	2,16	3,06	4,33	6,15	8,68
2,6	38	0,56	0,80	1,13	1,59	2,25	3,18	4,51	6,40	9,03
2,8	41	0,58	0,83	1,17	1,65	2,34	3,30	4,68	6,65	9,37
3	44	0,61	0,86	1,21	1,71	2,42	3,42	4,84	6,88	9,70
3,4	49	0,64	0,91	1,29	1,82	2,58	3,64	5,15	7,32	10,33
4	58	0,70	0,99	1,40	1,97	2,79	3,95	5,59	7,94	11,20
5	73	0,78	1,10	1,56	2,21	3,12	4,42	6,25	8,88	12,52
6	87	0,86	1,21	1,71	2,42	3,42	4,74	6,84	9,73	13,72
7	102	0,92	1,31	1,85	2,61	3,70	5,22	7,39	10,15	14,82
8	116	0,99	1,40	1,98	2,79	3,95	5,58	7,90	11,23	15,84
9	131	1,05	1,48	2,10	2,96	4,19	5,92	8,38	11,92	16,80

Ugello a specchio, largo angolo

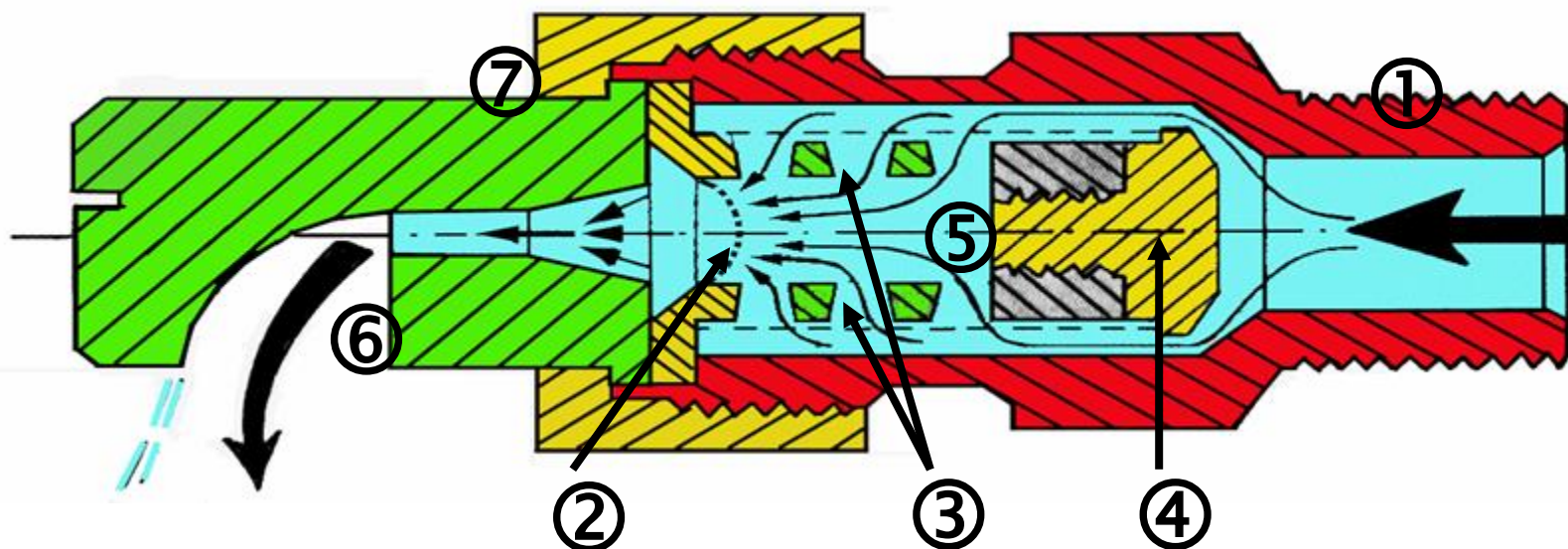

1 -Raccordo con la tubazione di alimentazione; 2 -Filtro; 3 -Canale di turbolenza; 4 -Rompiflusso; 5 -Camera di turbolenza; 6 -Foro a specchio; 7 - Ghiera di ancoraggio al raccordo.



***Ugello a
specchio,
largo angolo***

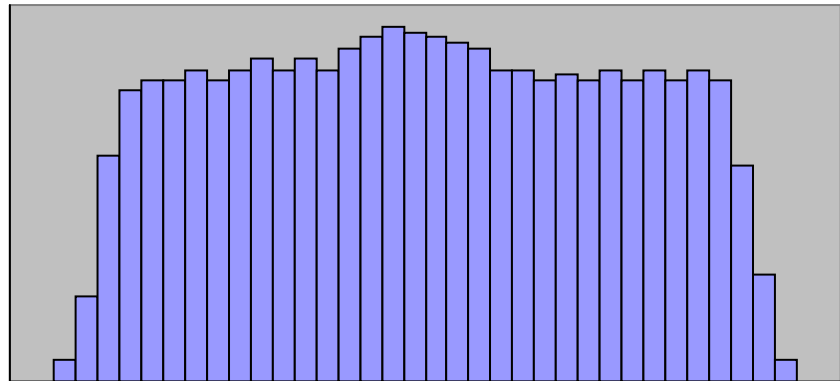
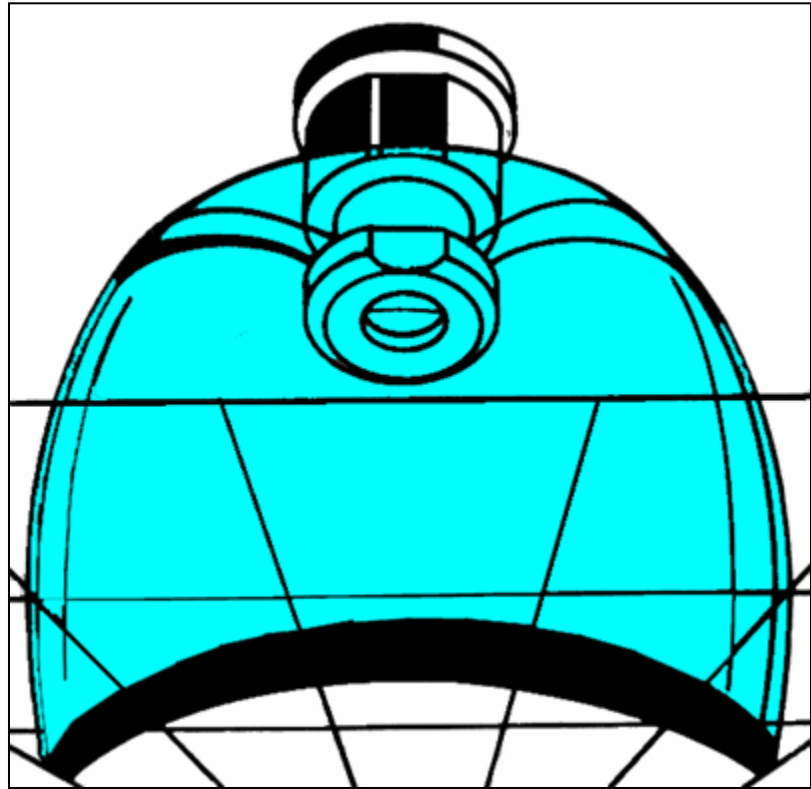

Ugello a specchio

- Turbulence chamber
- Tapered edge, wide angle flat pattern
- Designed to work in flat-fan nozzle holder
- Uniform spray distribution
- Wide pressure range
- Large, drift resistant droplets

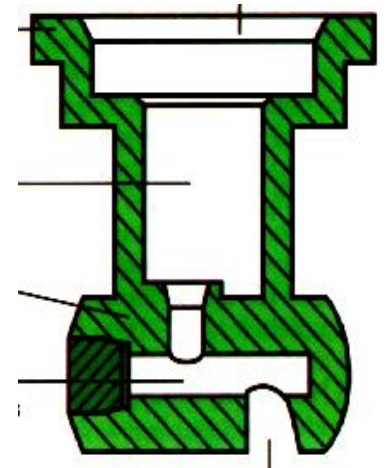

Diagrammi degli ugelli: riassunto

Cono

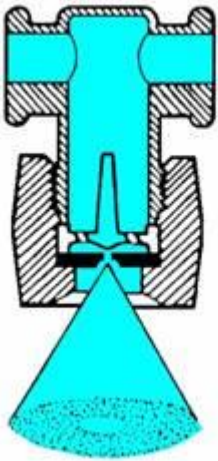

Ventaglio

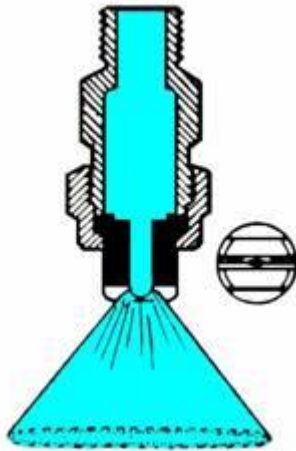

Applicazioni in banda

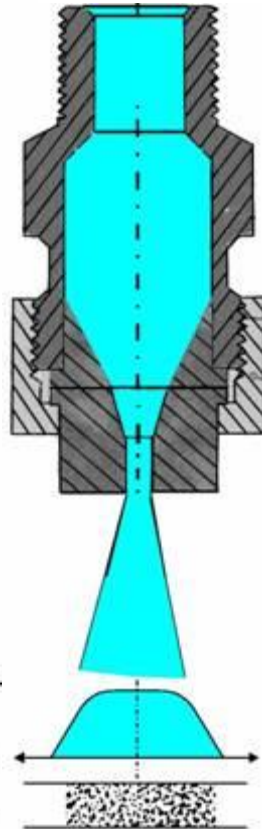

Specchio

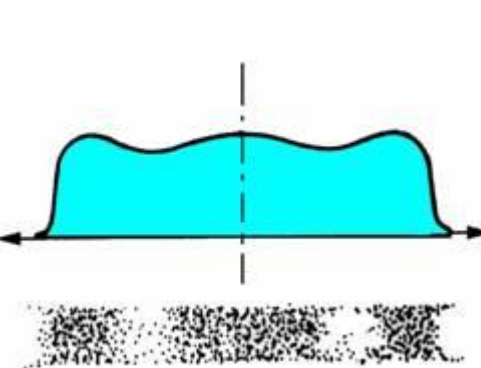
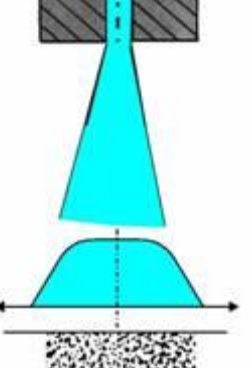
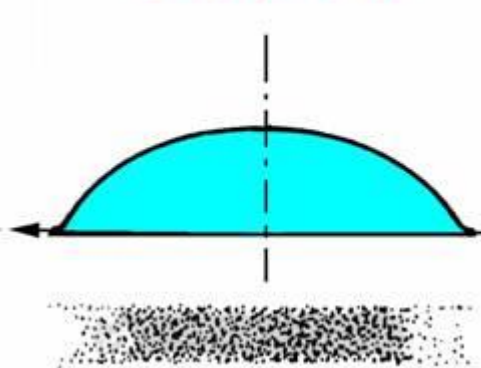
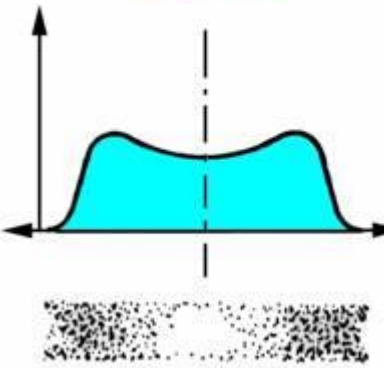
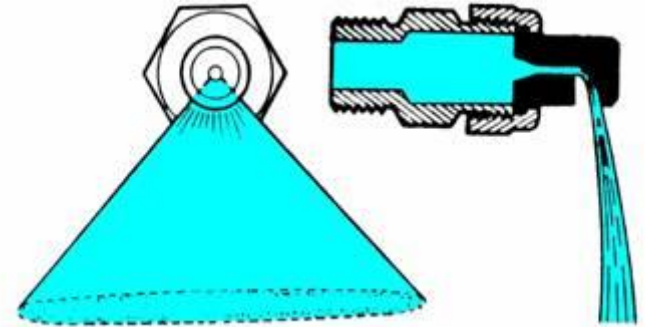

Sistema antigoccia sull'impianto

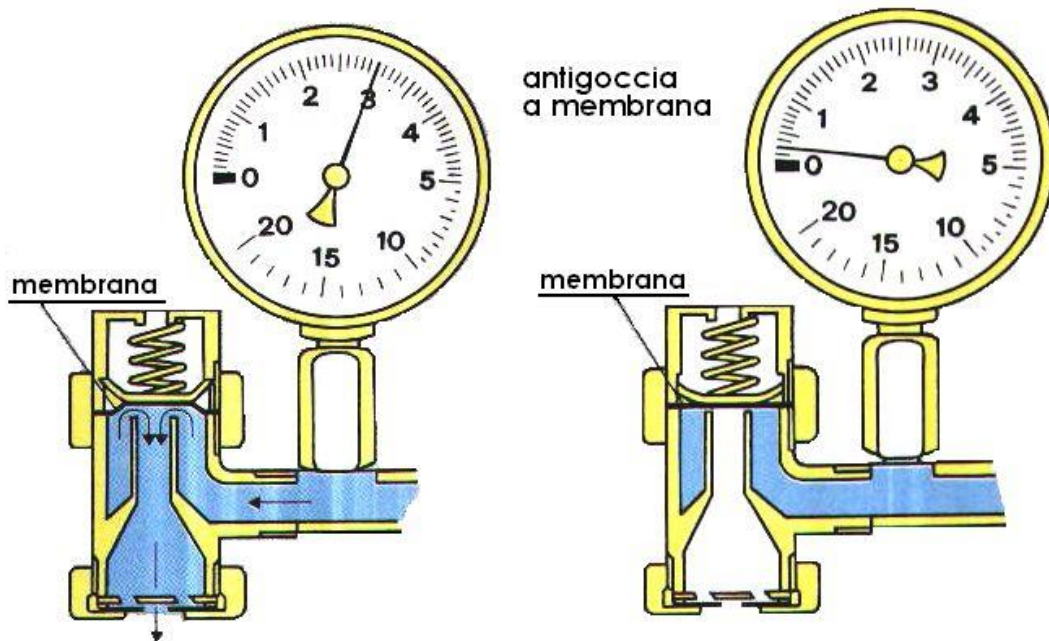

Sistemi antigoccia sull'ugello

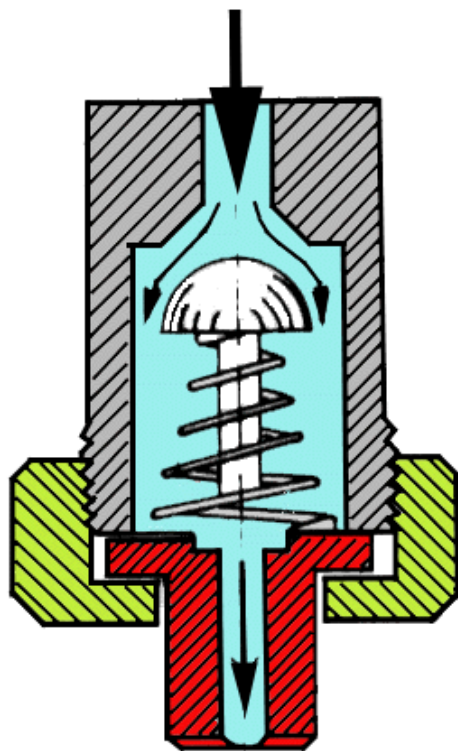

A valvola

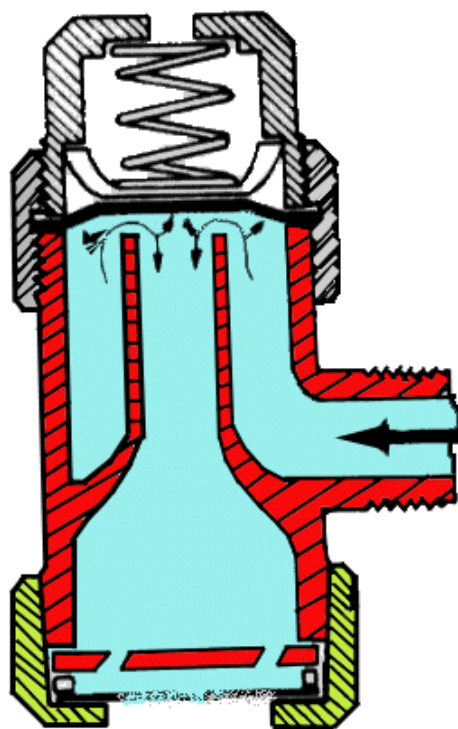

A membrana

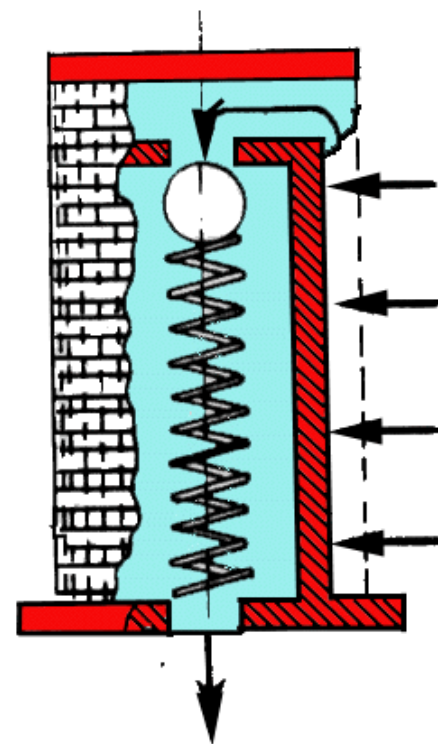

A sfera



Pneumatico

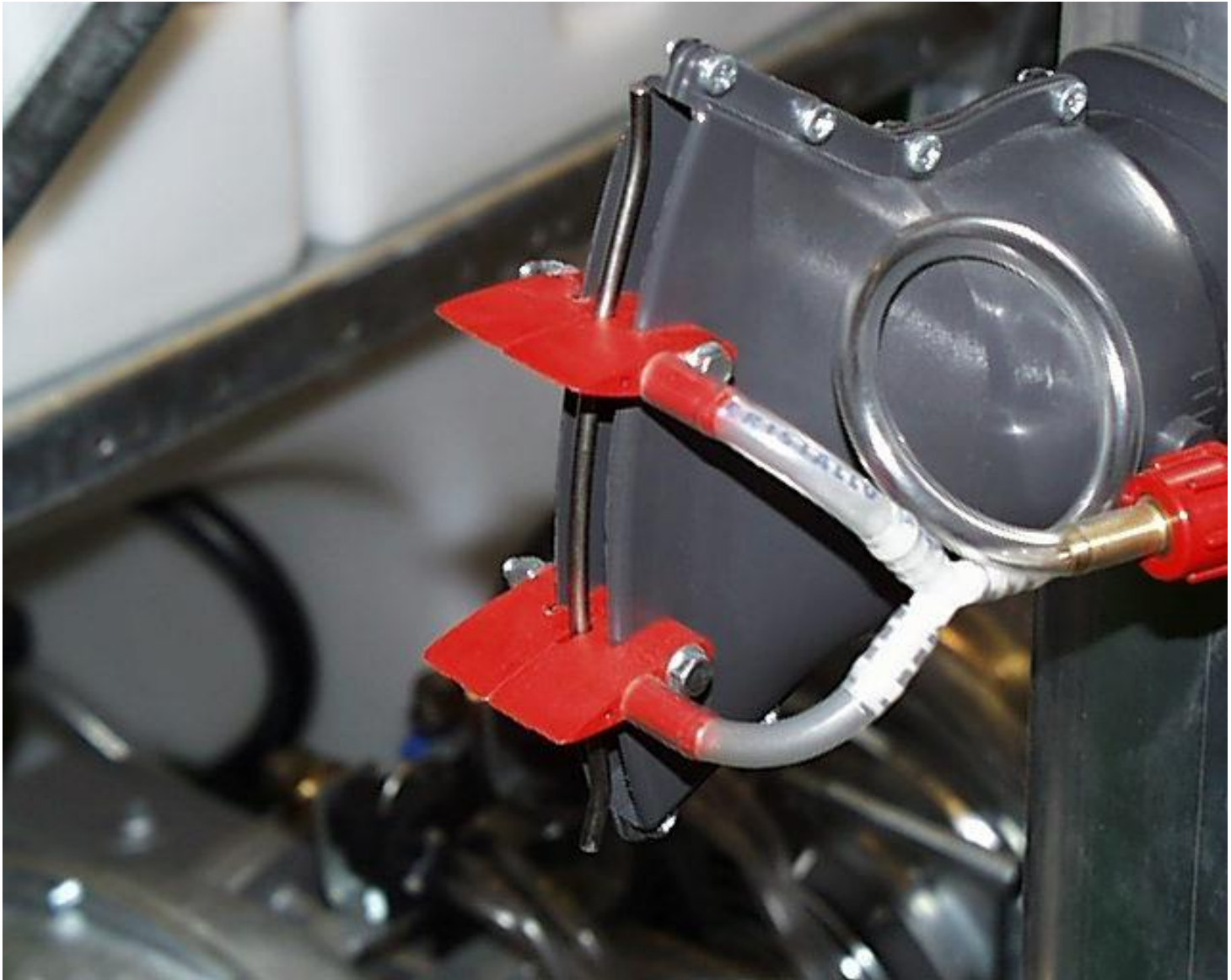



Centrifugo





Fonte Fantini Ing. Andreoli

Centrifugo per colture erbacee

1 -Carter di recupero;

2 -Disco;

3 -Alimentazione;

4 -Iniettore;

5 -Elettrovalvola.



GIROJET



Ugello centrifugo "MICROMAX"

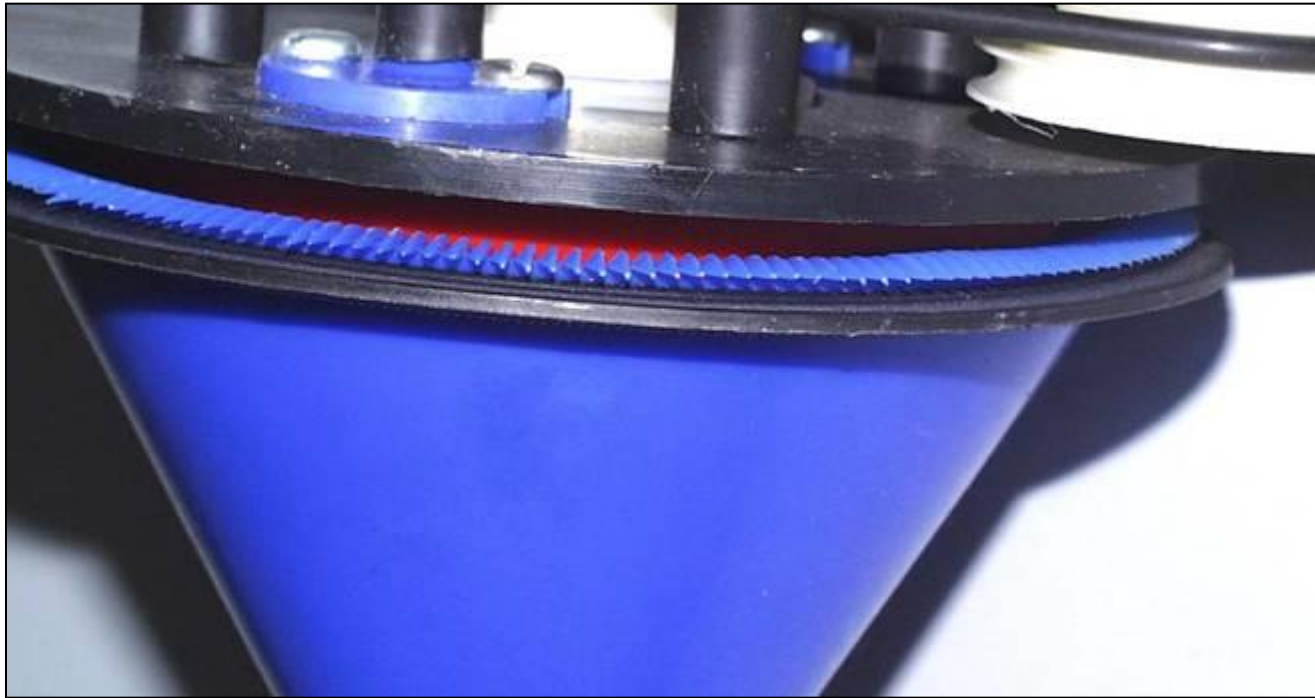

Scelta ugelli

Table 3. Nozzle guide for band and directed spraying.











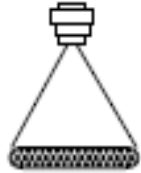

					
	Even Flat Fan	Twin Even Flat Fan	Hollow Cone	Full Cone	Disc and Core Cone
Herbicides					
Pre-emerge	Very Good	Good		Good	
Post-emerge Contact	Good	Very Good	Very Good		
Post-emerge Systemic	Very Good	Good			
Fungicides					
Contact	Good		Good		Very Good
Systemic	Very Good				Good
Insecticides					
Contact		Very Good	Very Good		Very Good
Systemic	Very Good				Good
Growth Regulators	Good			Very Good	

Table 2. Nozzle guide for broadcast spraying.

	 Extended Range Flat Fan	 Standard Flat Fan	 Drift Guard Flat Fan	 Twin Flat Fan	 Turbo Flood Wide Angle	 Wide Angle Full Core	 Flood Nozzle Wide Angle	 Raindrop Hollow Cone
Herbicides								
Soil-incorporated	Good		Very Good		Very Good	Very Good	Good	Good
Pre-emerge	Very Good <small>(at low pressure)</small>	Good	Very Good		Very Good	Very Good		Good
Post-emerge Contact	Good	Good		Very Good				
Post-emerge Systemic	Very Good <small>(at low pressure)</small>	Good	Very Good		Very Good			Good
Fungicides								
Contact	Very Good	Good						
Systemic	Very Good <small>(at low pressure)</small>		Very Good		Very Good			
Insecticides								
Contact	Good	Good		Very Good				
Systemic	Very Good <small>(at low pressure)</small>		Very Good		Very Good			

Ugello anti-deriva

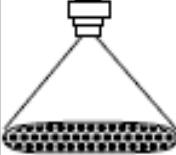

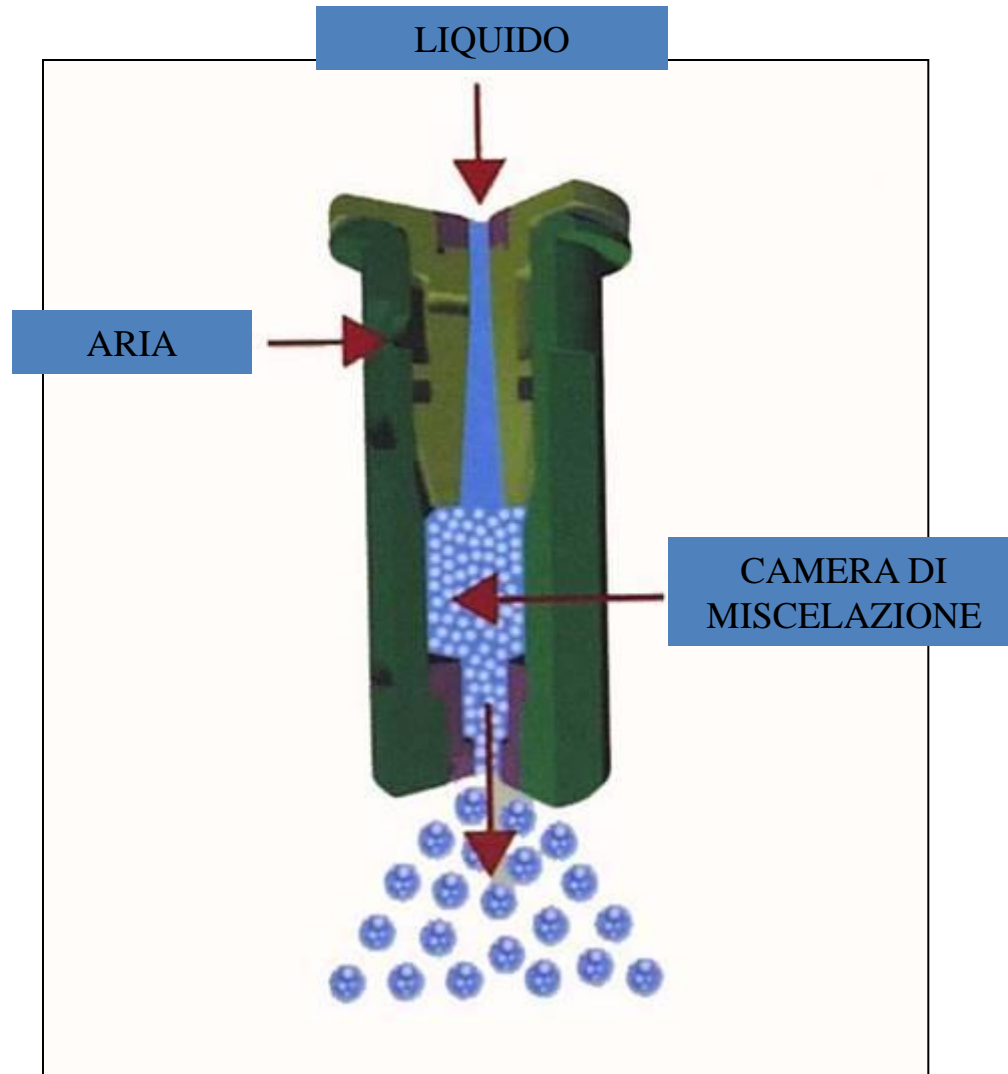

UGELLO "NOZAL"

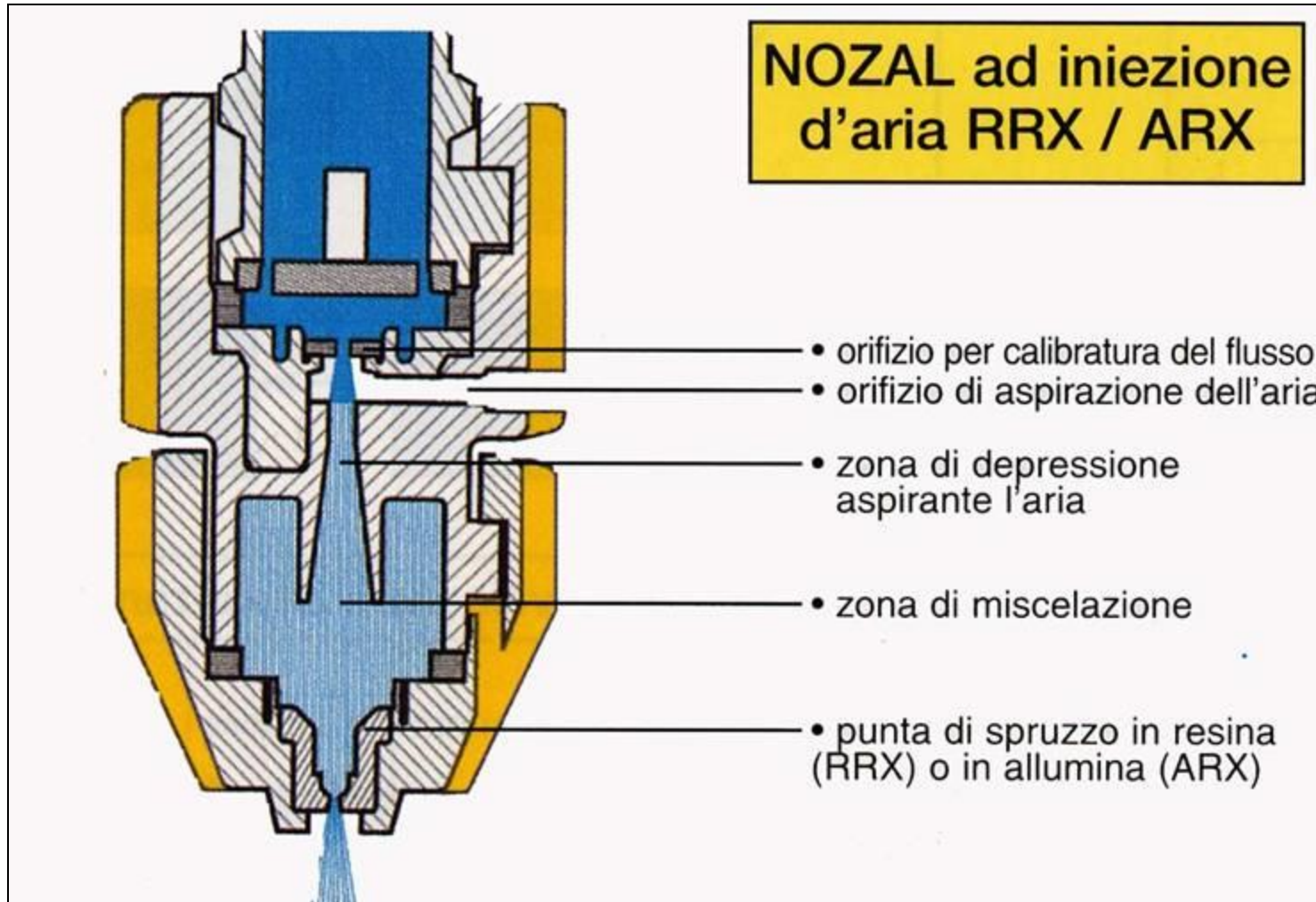



UGELLO TURBODROP

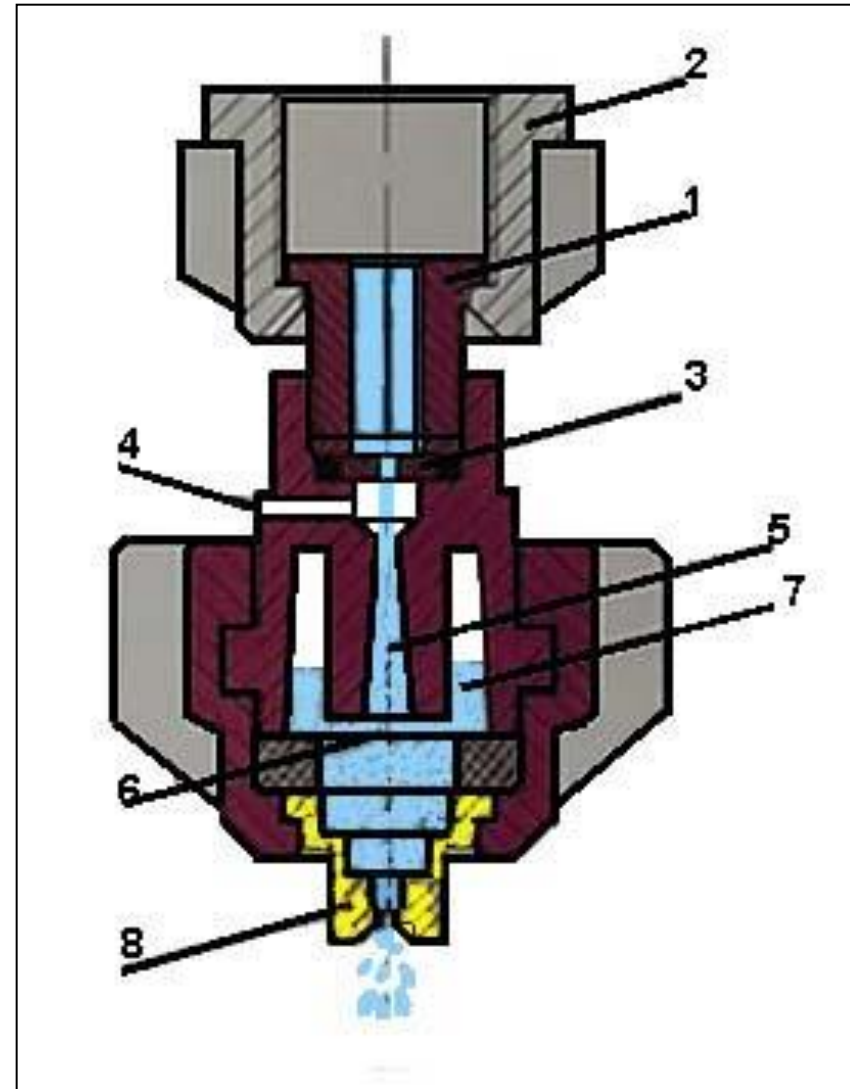

- 1 -Raccordo con la tubazione
- 2 -Adattatore
- 3 -Piastrina dosatrice
- 4 -Foro aspirazione - ingresso aria
- 5 -Camera turbolenza
- 6 -Zona di attenuazione
- 7 -Polmone compensatore
- 8 -Ugello terminale di distribuzione

Ugello By-Fluid



- Inject air into the fluid - by a second pump
- Low-pressure (8-9 psi)
- Designed to maintain drop size consistency
- Electronic controller will sense changes in pressure and maintain droplet size

UGELLO A PRESSIONE D'ARIA

1 -Raccordo
con la
tubazione;

2 -Piastrina;

3 -Ingresso
aria;

4 -Ghiera di
fissaggio al
raccordo.

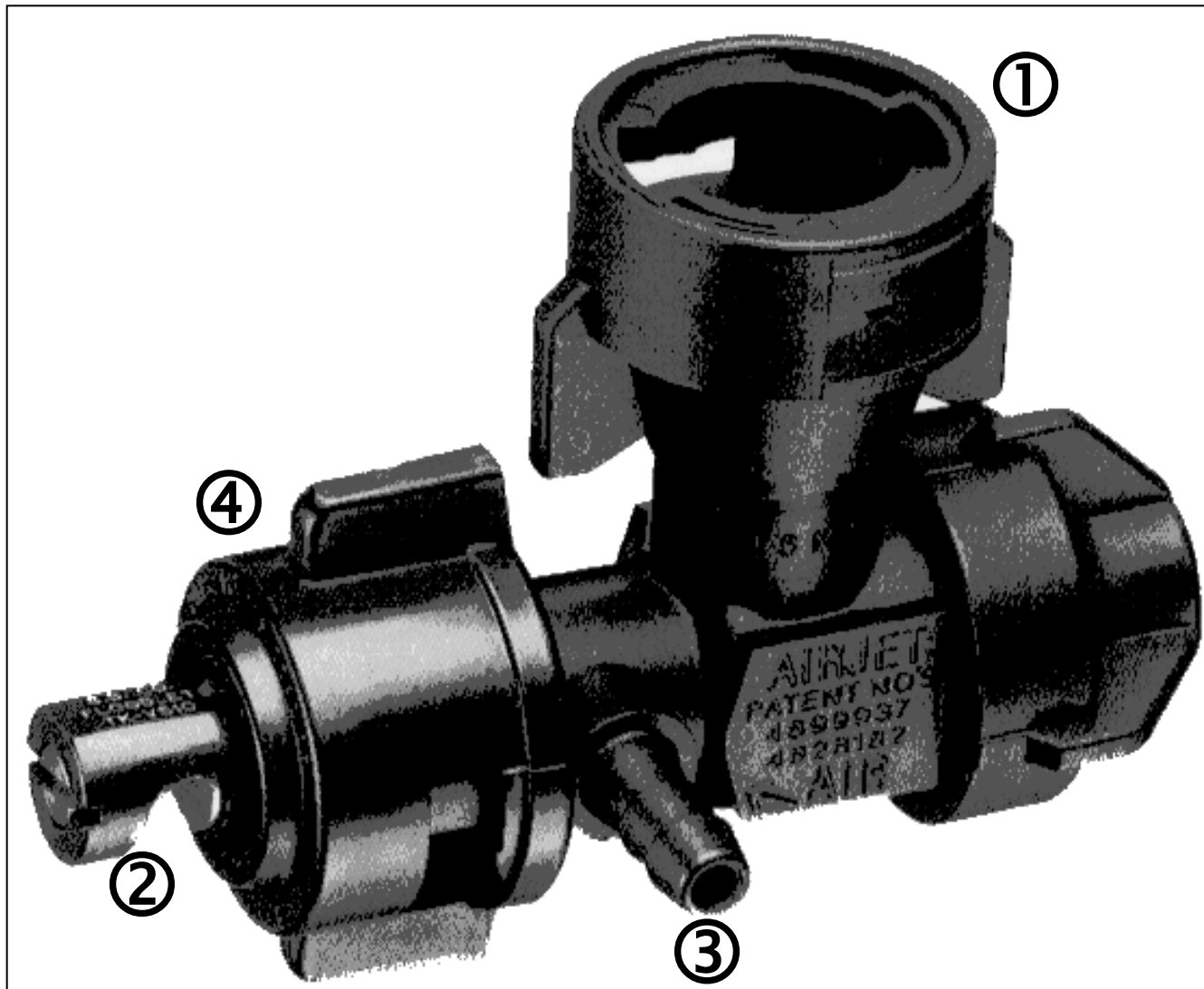

Evoluzione tecnologica delle irroratrici

- Una spinta significativa va nella direzione della **riduzione della deriva** e nell'aumento della **sicurezza per l'operatore**
- La maggior parte dei miglioramenti proviene da **applicazioni elettroniche ed informatiche** e dalla **tecnologia degli ugelli**



Tendenza evolutiva nella tecnologia dell'irrorazione

Applicazioni industriali derivano da:

- Costi per ha della protezione delle colture
- Riduzione volumi ettaro
- Più prodotti specifici
- Più disponibilità applicazioni elettroniche
- Impatto ambientale
- Legislazione
- Agricoltura di precisione





Irroratrici per colture erbacee















Irroratrici per colture arboree



































